

EE 330

Lecture 42

Digital Circuits

- Propagation Delay with Arbitrary Gate Sizing
- Optimally driving large capacitive loads

Exam Schedule

Exam 1	Friday Sept 24
Exam 2	Friday Oct 22
Exam 3	Friday Nov 19
Final	Tues Dec 14 12:00 p.m.

Photo courtesy of the director of the National Institute of Health (NIH)



As a courtesy to fellow classmates, TAs, and the instructor

Wearing of masks during lectures and in the laboratories for this course would be appreciated irrespective of vaccination status

Final Tues Dec 14 (scheduled 12:00 pm)

Final Exam will be distributed by 8:00 AM on the day of exam and due on Canvas at 2:15 PM

This will be structured as a 2-hour in-person exam following the same format as the final exam from previous semesters that are posted on the class website.

Students will be expected to comply with the honor system as stipulated on previous exams in this course. If anyone is unwilling to comply with the honor system, please let me know by Friday December 10 so that alternative arrangements can be made for taking the final exam. A grade of 0 along with other sanctions will be assessed for anyone that does not comply with the honor system on this exam.

The Reference Inverter

Reference Inverter

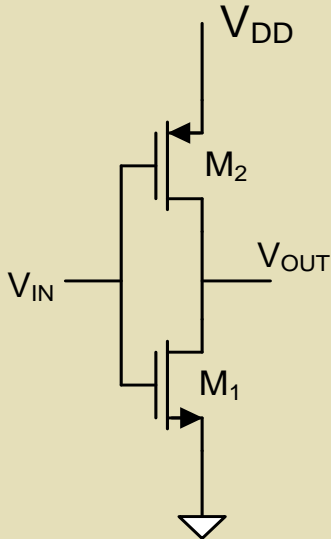

Assume $\mu_n/\mu_p=3$

$W_n=W_{MIN}$, $W_p=3W_{MIN}$

$L_n=L_p=L_{MIN}$

In 0.5u proc $t_{REF}=20ps$,

$C_{REF}=4fF$, $R_{PDREF}=R_{PUREF}=2.5K$

$$R_{PDREF}=R_{PUREF}$$

$$C_{REF}=C_{IN}=4C_{OX}W_{MIN}L_{MIN}$$

$$R_{PDREF}=\frac{L_{MIN}}{\mu_n C_{OX} W_{MIN} (V_{DD}-V_{Tn})} \stackrel{V_{Tn}=.2V_{DD}}{=} \frac{L_{MIN}}{\mu_n C_{OX} W_{MIN} (0.8V_{DD})}$$

$$t_{HLREF}=t_{LHREF}=R_{PDREF}C_{REF}$$

$$t_{REF}=t_{HLREF}+t_{LHREF}=2R_{PDREF}C_{REF}$$

(Note: This C_{OX} is somewhat larger than that in the 0.5u ON process)

Device Sizing

Equal Worst-Case Rise/Fall Device Sizing Strategy

-- (same as $V_{TRIP}=V_{DD}/2$ for worst case delay in typical process considered in example)

Assume $\mu_n/\mu_p=3$ **How many degrees of freedom were available?**

$L_n=L_p=L_{MIN}$

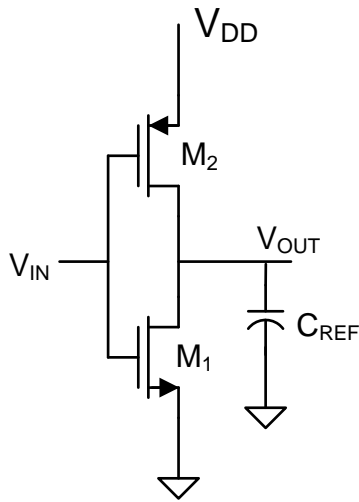

INV

$W_n=W_{MIN}, W_p=3W_{MIN}$

$C_{IN}=C_{REF}$

$FI=1$

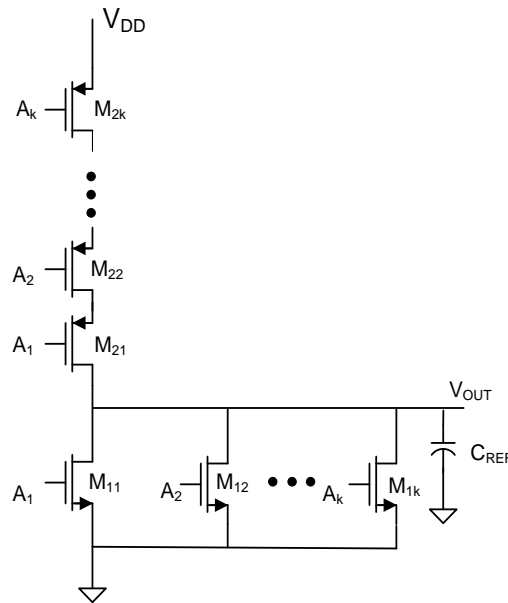

k-input NOR

$W_n=W_{MIN}, W_p=3kW_{MIN}$

$C_{IN}=\left(\frac{3k+1}{4}\right)C_{REF}$

$FI=\left(\frac{3k+1}{4}\right)$

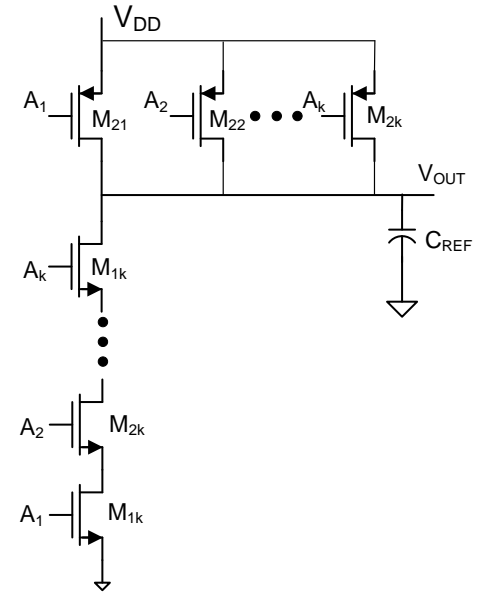

k-input NAND

$W_n=kW_{MIN}, W_p=3W_{MIN}$

$C_{IN}=\left(\frac{3+k}{4}\right)C_{REF}$

$FI=\left(\frac{3+k}{4}\right)$

Overdrive Factors

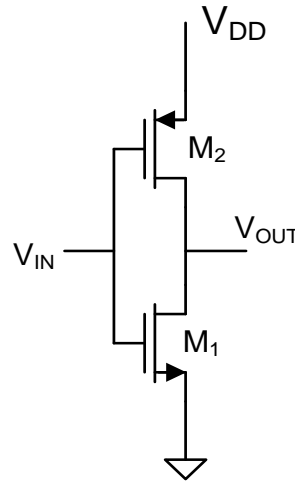

Scaling widths of ALL devices by constant ($W_{\text{scaled}}=W \times \text{OD}$) will change “drive” capability relative to that of the reference inverter but not change relative value of t_{HL} and t_{LH}

$$R_{\text{PD}} = \frac{L_1}{\mu_n C_{\text{OX}} W_1 (V_{\text{DD}} - V_{\text{Tn}})}$$



$$R_{\text{PDOD}} = \frac{L_1}{\mu_n C_{\text{OX}} [\text{OD} \cdot W_1] (V_{\text{DD}} - V_{\text{Tn}})} = \frac{R_{\text{PD}}}{\text{OD}}$$

$$R_{\text{PU}} = \frac{L_2}{\mu_p C_{\text{OX}} W_2 (V_{\text{DD}} + V_{\text{Tp}})}$$



$$R_{\text{PUOD}} = \frac{L_2}{\mu_p C_{\text{OX}} [\text{OD} \cdot W_2] (V_{\text{DD}} + V_{\text{Tp}})} = \frac{R_{\text{PU}}}{\text{OD}}$$

Scaling widths of ALL devices by constant will change FI by OD

$$C_{\text{IN}} = C_{\text{OX}} (W_1 L_1 + W_2 L_2)$$



$$C_{\text{INOD}} = C_{\text{OX}} ([\text{OD} \cdot W_1] L_1 + [\text{OD} \cdot W_2] L_2) = \text{OD} \cdot C_{\text{IN}}$$

Propagation Delay with Over-drive Capability

Example

Compare the propagation delays. Assume the OD is 900 in the third case and 30 in the fourth case. Don't worry about the extra inversion at this time.

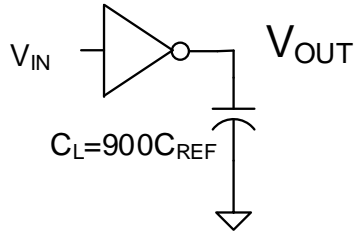

$$t_{PROP} = 900t_{REF}$$

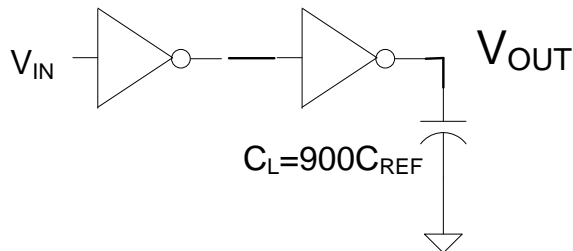

$$t_{PROP} = t_{REF} + 900t_{REF} = 901t_{REF}$$

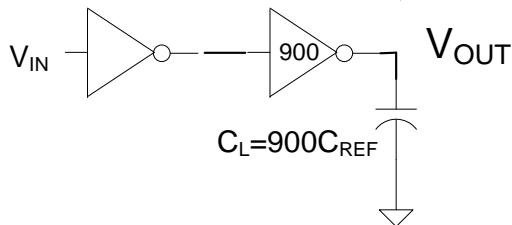

$$t_{PROP} = 900t_{REF} + t_{REF} = 901t_{REF}$$

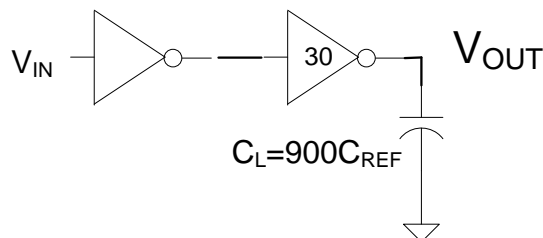

$$t_{PROP} = 30t_{REF} + 30t_{REF} = 60t_{REF}$$

Note: Dramatic reduction in t_{PROP} is possible

Will later determine what optimal number of stages and sizing is

Propagation Delay in Multiple-Levels of Logic with Stage Loading

Will consider an example with the five cases

- Equal rise/fall (no overdrive)
- Equal rise/fall with overdrive
- Minimum Sized
- Asymmetric Overdrive
- Combination of equal rise/fall, minimum size and overdrive

Will develop the analysis methods as needed

Propagation Delay in Multiple-Levels of Logic with Stage Loading

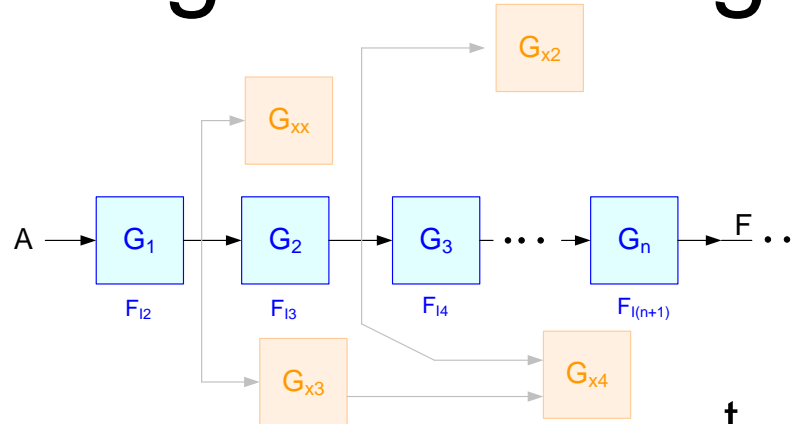

- Equal rise/fall (no overdrive)

$$t_{\text{PROP}} = t_{\text{REF}} \sum_{k=1}^n F_{I(k+1)}$$

- Equal rise/fall with overdrive

$$t_{\text{PROP}} = t_{\text{REF}} \sum_{k=1}^n \frac{F_{I(k+1)}}{\text{OD}_k}$$

- Minimum Sized

$$t_{\text{PROP}} = ?$$

- Asymmetric Overdrive

$$t_{\text{PROP}} = t_{\text{REF}} \cdot \left(\frac{1}{2} \sum_{k=1}^n F_{I(k+1)} \left(\frac{1}{\text{OD}_{\text{HLK}}} + \frac{1}{\text{OD}_{\text{LHK}}} \right) \right)$$

- Combination of equal rise/fall, minimum size and overdrive

$$t_{\text{PROP}} = ?$$

Propagation Delay in Multiple-Levels of Logic with Stage Loading

Equal rise-fall gates, no overdrive

	Equal Rise/Fall
C_{IN}/C_{REF}	
Inverter	1
NOR	$\frac{3k+1}{4}$
NAND	$\frac{3+k}{4}$
Overdrive	
Inverter	
HL	1
LH	1
NOR	
HL	1
LH	1
NAND	
HL	1
LH	1
t_{PROP}/t_{REF}	$\sum_{k=1}^n F_{(k+1)}$

Review from Last Time
 Equal rise-fall gates, no overdrive

In 0.5u proc $t_{REF}=20ps$,
 $C_{REF}=4fF, R_{PDREF}=2.5K$

(Note: This C_{OX} is somewhat larger than that in the 0.5u ON process)

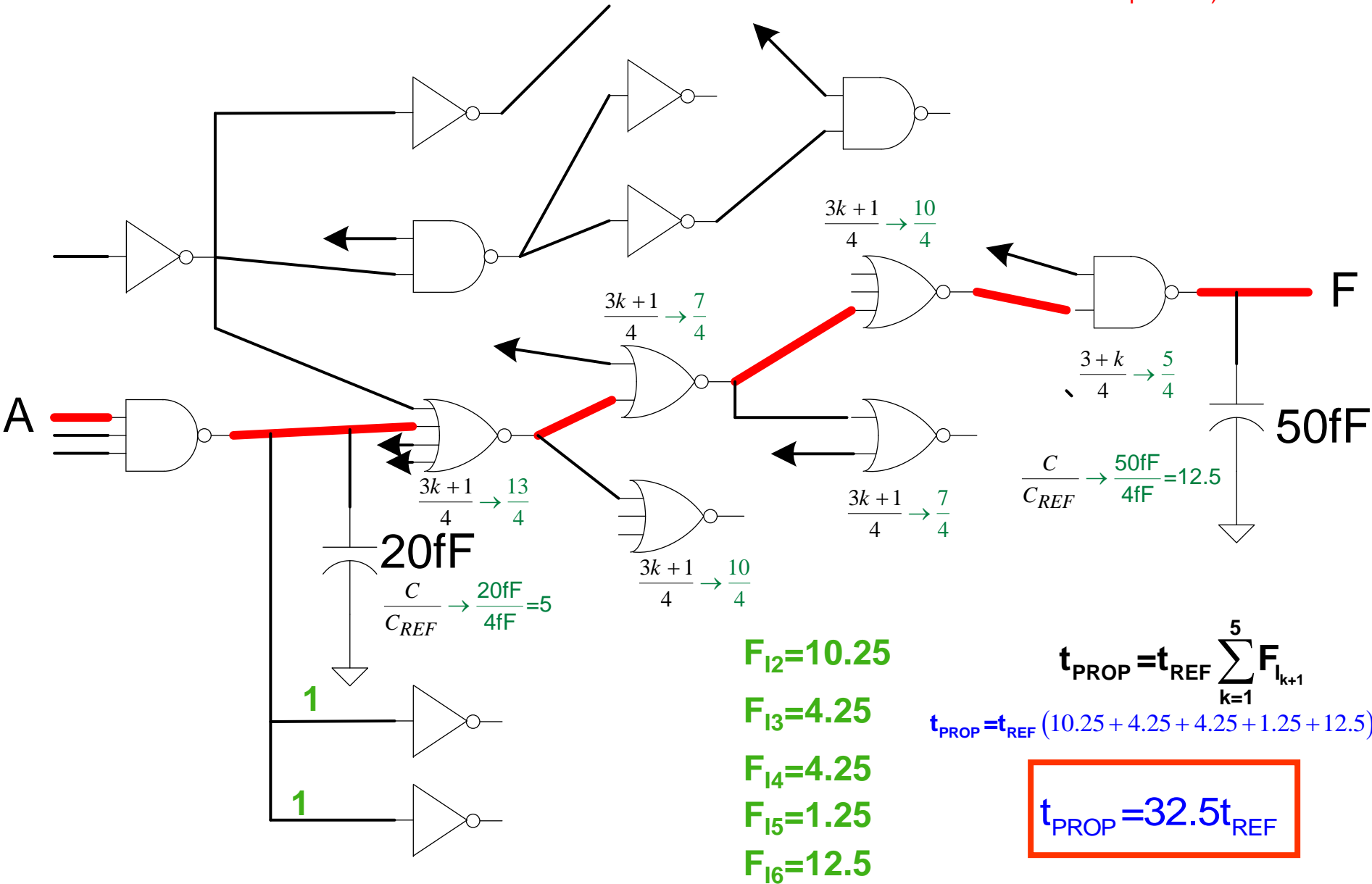

Propagation Delay in Multiple-Levels of Logic with Stage Loading

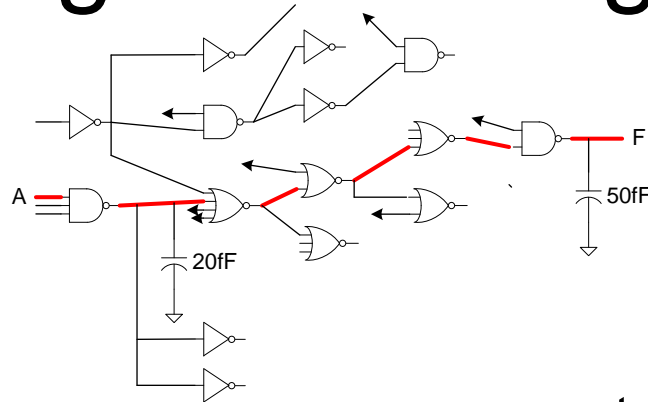

- Equal rise/fall (no overdrive)

$$t_{\text{PROP}} = t_{\text{REF}} \sum_{k=1}^n F_{l(k+1)}$$



- Equal rise/fall with overdrive

$$t_{\text{PROP}} = t_{\text{REF}} \sum_{k=1}^n \frac{F_{l(k+1)}}{\text{OD}_k}$$



- Minimum Sized

$$t_{\text{PROP}} = ?$$

- Asymmetric Overdrive

$$t_{\text{PROP}} = t_{\text{REF}} \cdot \left(\frac{1}{2} \sum_{k=1}^n F_{l(k+1)} \left(\frac{1}{\text{OD}_{\text{HLk}}} + \frac{1}{\text{OD}_{\text{LHk}}} \right) \right)$$

- Combination of equal rise/fall, minimum size and overdrive

$$t_{\text{PROP}} = ?$$

Propagation Delay in Multiple-Levels of Logic with Stage Loading

Equal rise-fall gates, with overdrive

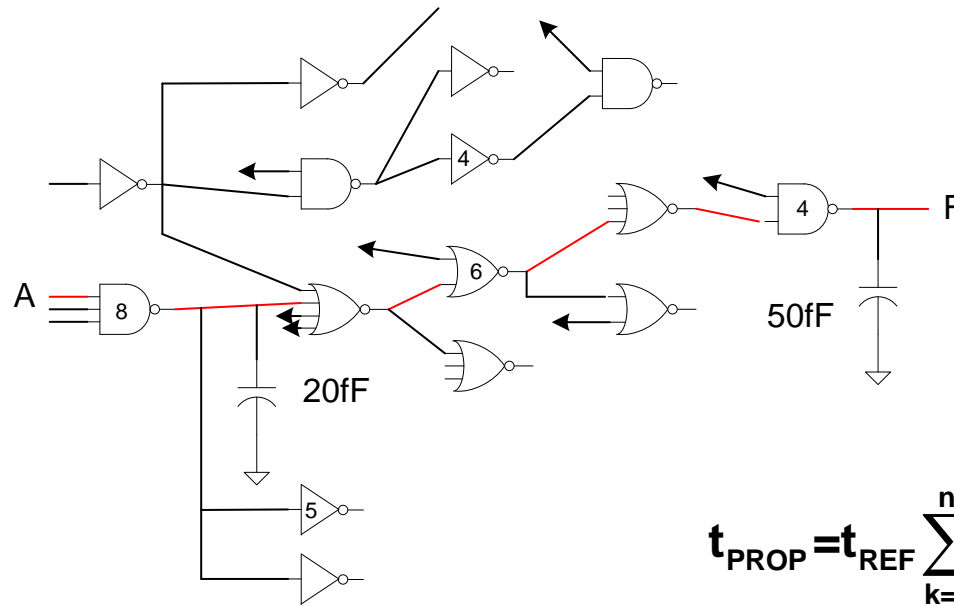

$$t_{\text{PROP}} = t_{\text{REF}} \sum_{k=1}^n \frac{F_{l_{k+1}}}{\text{OD}_k}$$



$$\frac{t_{\text{PROP}}}{t_{\text{REF}}} = \sum_{k=1}^n \frac{F_{l_{k+1}}}{\text{OD}_k}$$

In 0.5u proc $t_{\text{REF}}=20\text{ps}$, $C_{\text{REF}}=4\text{fF}$, $R_{\text{PDREF}}=2.5\text{K}$

(Note: This C_{OX} is somewhat larger than that in the 0.5u ON process)

Propagation Delay in Multiple-Levels of Logic with Stage Loading

Equal rise-fall gates, with overdrive

	Equal Rise/Fall	Equal Rise/Fall (with OD)
C_{IN}/C_{REF}		
Inverter	1	OD
NOR	$\frac{3k+1}{4}$	$\frac{3k+1}{4} \cdot OD$
NAND	$\frac{3+k}{4}$	$\frac{3+k}{4} \cdot OD$
Overdrive		
Inverter		
HL	1	OD
LH	1	OD
NOR		
HL	1	OD
LH	1	OD
NAND		
HL	1	OD
LH	1	OD
t_{PROP}/t_{REF}	$\sum_{k=1}^n F_{l(k+1)}$	$\sum_{k=1}^n \frac{F_{l(k+1)}}{OD_k}$

Equal rise-fall gates, with overdrive

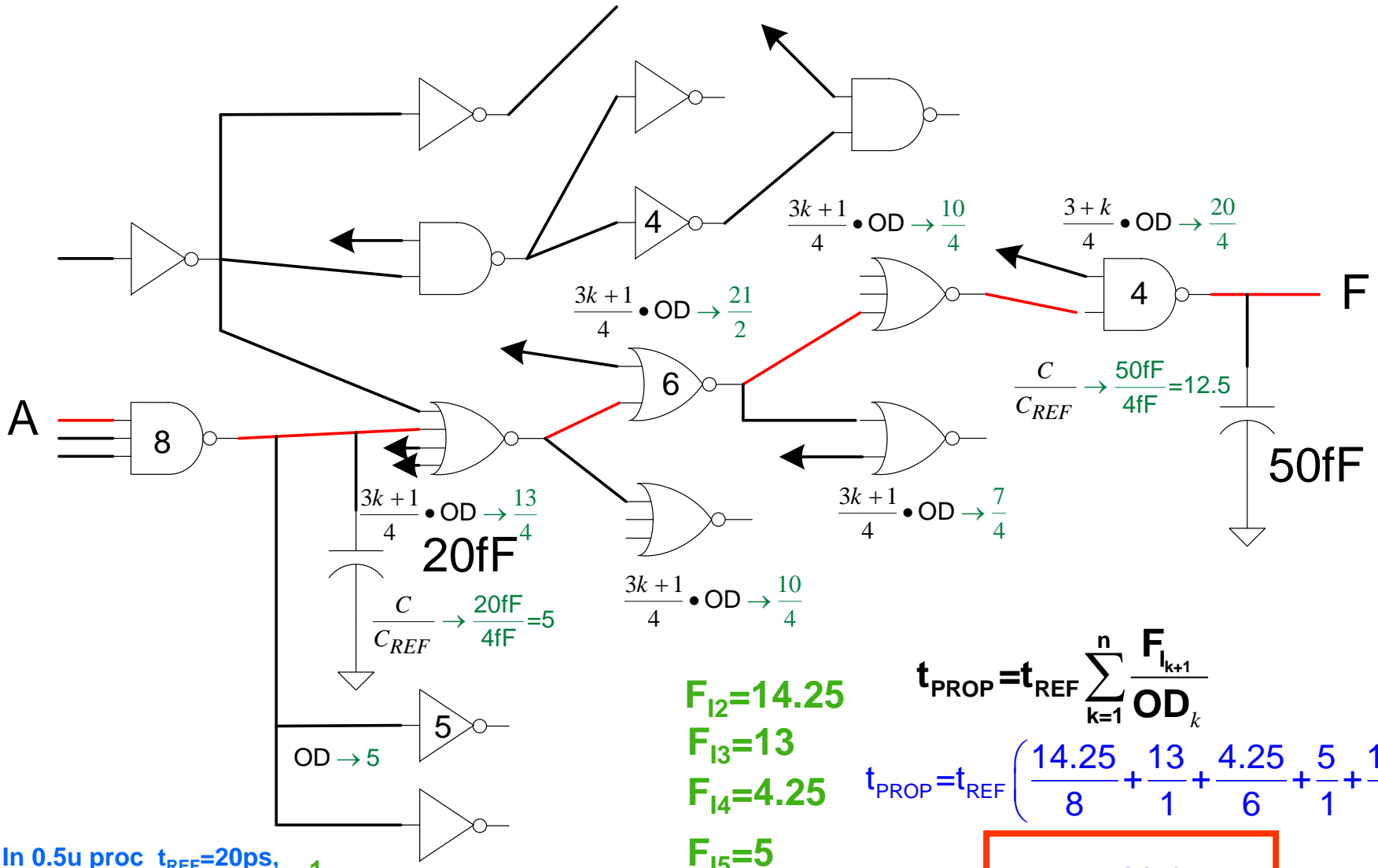

In 0.5u proc $t_{REF} = 20ps$, $C_{REF} = 4fF, R_{PDREF} = 2.5K$

(Note: This C_{OX} is somewhat larger than that in the 0.5u ON process)

Propagation Delay in Multiple-Levels of Logic with Stage Loading

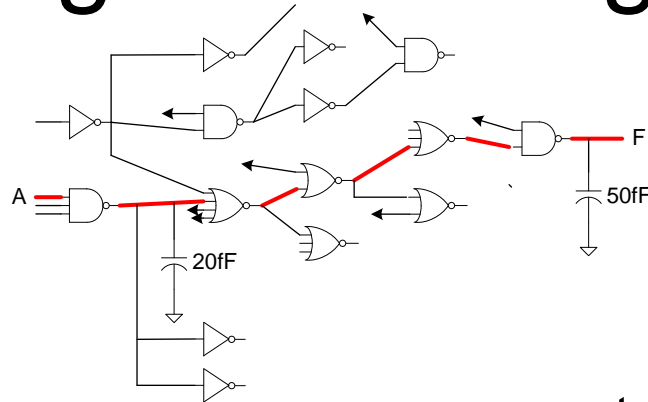

- Equal rise/fall (no overdrive)

$$t_{\text{PROP}} = t_{\text{REF}} \sum_{k=1}^n F_{I(k+1)}$$

- Equal rise/fall with overdrive

$$t_{\text{PROP}} = t_{\text{REF}} \sum_{k=1}^n \frac{F_{I(k+1)}}{\text{OD}_k}$$



- Minimum Sized

$$t_{\text{PROP}} = ?$$

- Asymmetric Overdrive

$$t_{\text{PROP}} = t_{\text{REF}} \cdot \left(\frac{1}{2} \sum_{k=1}^n F_{I(k+1)} \left(\frac{1}{\text{OD}_{\text{HLk}}} + \frac{1}{\text{OD}_{\text{LHk}}} \right) \right)$$

- Combination of equal rise/fall, minimum size and overdrive

$$t_{\text{PROP}} = ?$$

Propagation Delay in Multiple-Levels of Logic with Stage Loading

Minimum-sized gates

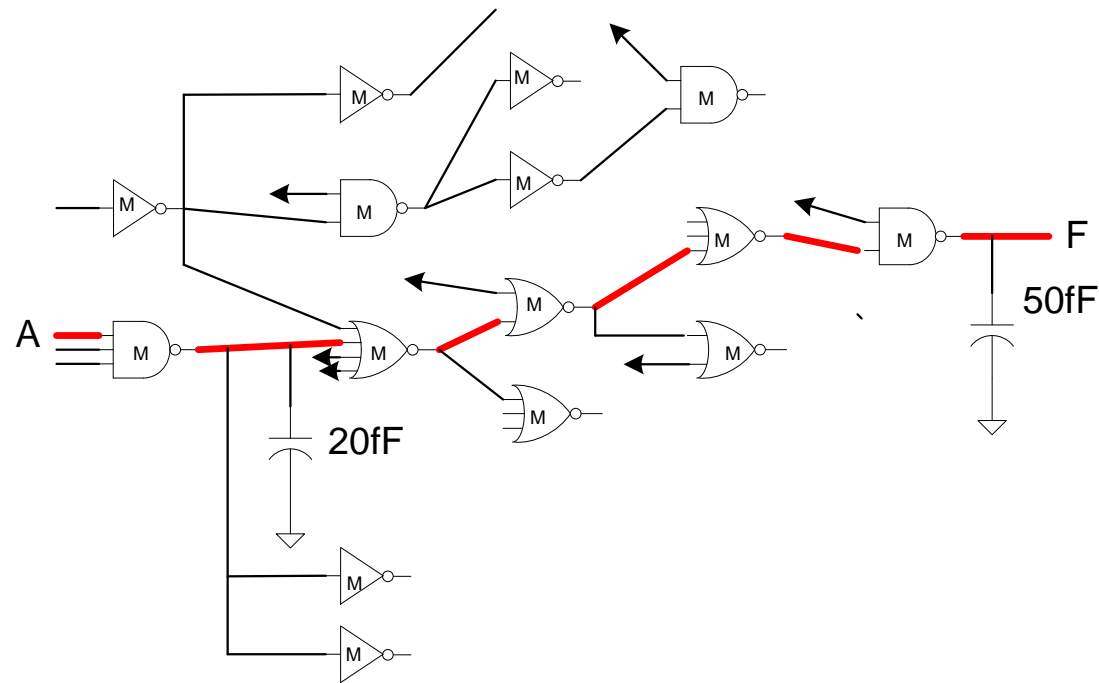

$$t_{\text{PROP}} = t_{\text{REF}} \bullet ?$$

Observe that a minimum-sized gate is simply a gate with asymmetric overdrive

Recall:

Propagation Delay with Minimum-Sized Gates

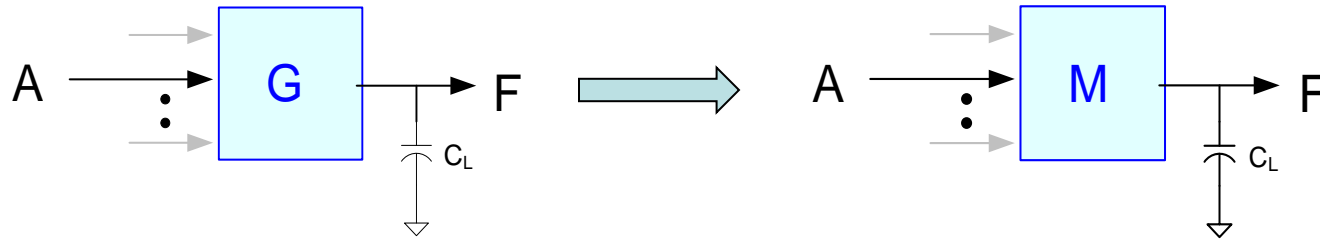

$$t_{\text{PROP}} = t_{\text{REF}} \cdot \left(\frac{1}{2} \sum_{k=1}^n F_{I(k+1)} \left(\frac{1}{\text{OD}_{\text{HLk}}} + \frac{1}{\text{OD}_{\text{LHk}}} \right) \right)$$



$$\frac{t_{\text{PROP}}}{t_{\text{REF}}} = \left(\frac{1}{2} \sum_{k=1}^n F_{I(k+1)} \left(\frac{1}{\text{OD}_{\text{HLk}}} + \frac{1}{\text{OD}_{\text{LHk}}} \right) \right)$$

- Still need OD_{HL} and OD_{LH} for minimum-sized gates
- Still need FI for minimum-sized gates

Propagation Delay with minimum-sized gates

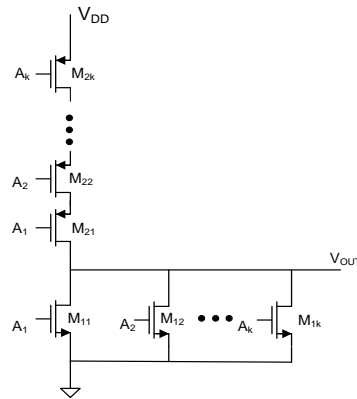
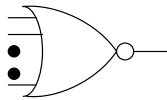

$$OD_{HL}=?$$

$$OD_{HL}=1$$

$$OD_{LH}=?$$

$$OD_{LH}=\frac{1}{3k}$$

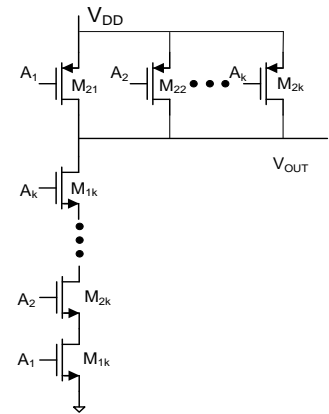
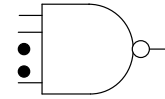

$$OD_{HL}=?$$

$$OD_{HL}=1/k$$

$$OD_{LH}=?$$

$$OD_{LH}=\frac{1}{3}$$

$$FI=2C_{OX}W_{MIN}L_{MIN}$$

$$C_{REF}=4C_{OX}W_{MIN}L_{MIN}$$

$$FI=\frac{C_{REF}}{2}$$

Propagation Delay in Multiple-Levels of Logic with Stage Loading

Minimum-sized gates

	Equal Rise/Fall	Equal Rise/Fall (with OD)	Minimum Sized
C_{IN}/C_{REF}			
Inverter	1	OD	
NOR	$\frac{3k+1}{4}$	$\frac{3k+1}{4} \cdot OD$	
NAND	$\frac{3+k}{4}$	$\frac{3+k}{4} \cdot OD$	
Overdrive			
Inverter			
HL	1	OD	
LH	1	OD	
NOR			
HL	1	OD	
LH	1	OD	
NAND			
HL	1	OD	
LH	1	OD	
t_{PROP}/t_{REF}	$\sum_{k=1}^n F_{l(k+1)}$	$\sum_{k=1}^n \frac{F_{l(k+1)}}{OD_k}$	

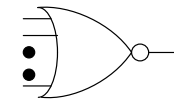

$$OD_{HL} = 1$$

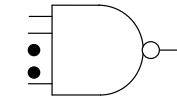

$$OD_{HL} = 1/k$$

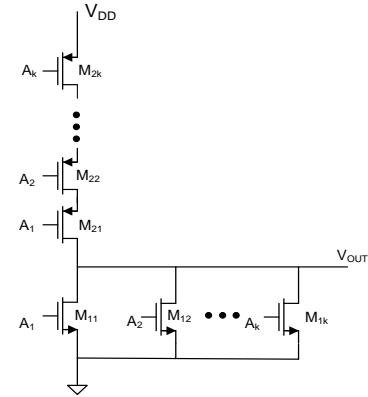

$$OD_{LH} = \frac{1}{3k}$$

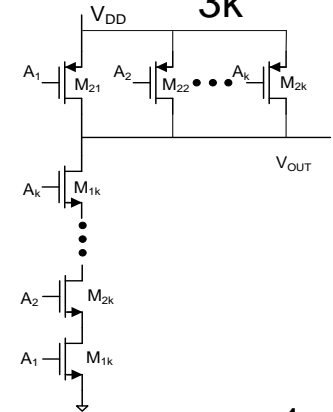

$$OD_{LH} = \frac{1}{3}$$

$$FI = \frac{C_{REF}}{2}$$

Propagation Delay in Multiple-Levels of Logic with Stage Loading

Minimum-sized gates

	Equal Rise/Fall	Equal Rise/Fall (with OD)	Minimum Sized
C_{IN}/C_{REF}			
Inverter	1	OD	1/2
NOR	$\frac{3k+1}{4}$	$\frac{3k+1}{4} \cdot OD$	1/2
NAND	$\frac{3+k}{4}$	$\frac{3+k}{4} \cdot OD$	1/2
Overdrive			
Inverter			
HL	1	OD	1
LH	1	OD	1/3
NOR			
HL	1	OD	1
LH	1	OD	1/(3k)
NAND			
HL	1	OD	1/k
LH	1	OD	1/3
t_{PROP}/t_{REF}	$\sum_{k=1}^n F_{l(k+1)}$	$\sum_{k=1}^n \frac{F_{l(k+1)}}{OD_k}$	$\frac{1}{2} \sum_{k=1}^n F_{l(k+1)} \left(\frac{1}{OD_{HLk}} + \frac{1}{OD_{LHk}} \right)$

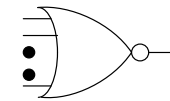

$$OD_{HL} = 1$$

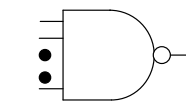

$$OD_{HL} = 1/k$$

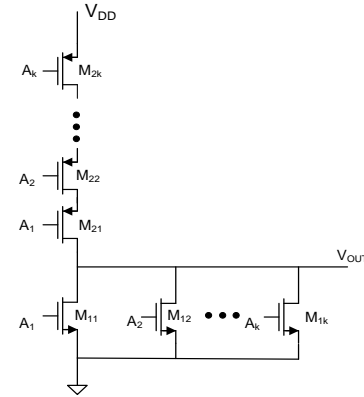

$$OD_{LH} = \frac{1}{3k}$$

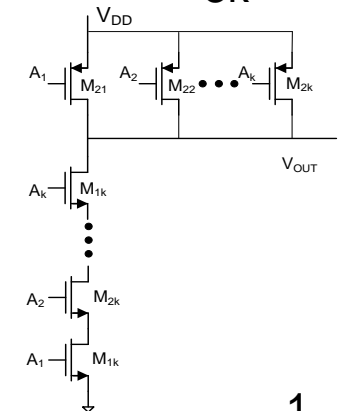

$$OD_{LH} = \frac{1}{3}$$

$$FI = \frac{C_{REF}}{2}$$

Propagation Delay in Multiple-Levels of Logic with Stage Loading

Minimum-sized gates

	Equal Rise/Fall	Equal Rise/Fall (with OD)	Minimum Sized
C_{IN}/C_{REF}			
Inverter	1	OD	1/2
NOR	$\frac{3k+1}{4}$	$\frac{3k+1}{4} \cdot OD$	1/2
NAND	$\frac{3+k}{4}$	$\frac{3+k}{4} \cdot OD$	1/2
Overdrive			
Inverter			
HL	1	OD	1
LH	1	OD	1/3
NOR			
HL	1	OD	1
LH	1	OD	1/(3k)
NAND			
HL	1	OD	1/k
LH	1	OD	1/3
t_{PROP}/t_{REF}	$\sum_{k=1}^n F_{l(k+1)}$	$\sum_{k=1}^n \frac{F_{l(k+1)}}{OD_k}$	$\frac{1}{2} \sum_{k=1}^n F_{l(k+1)} \left(\frac{1}{OD_{HLk}} + \frac{1}{OD_{LHk}} \right)$

Minimum-sized gates

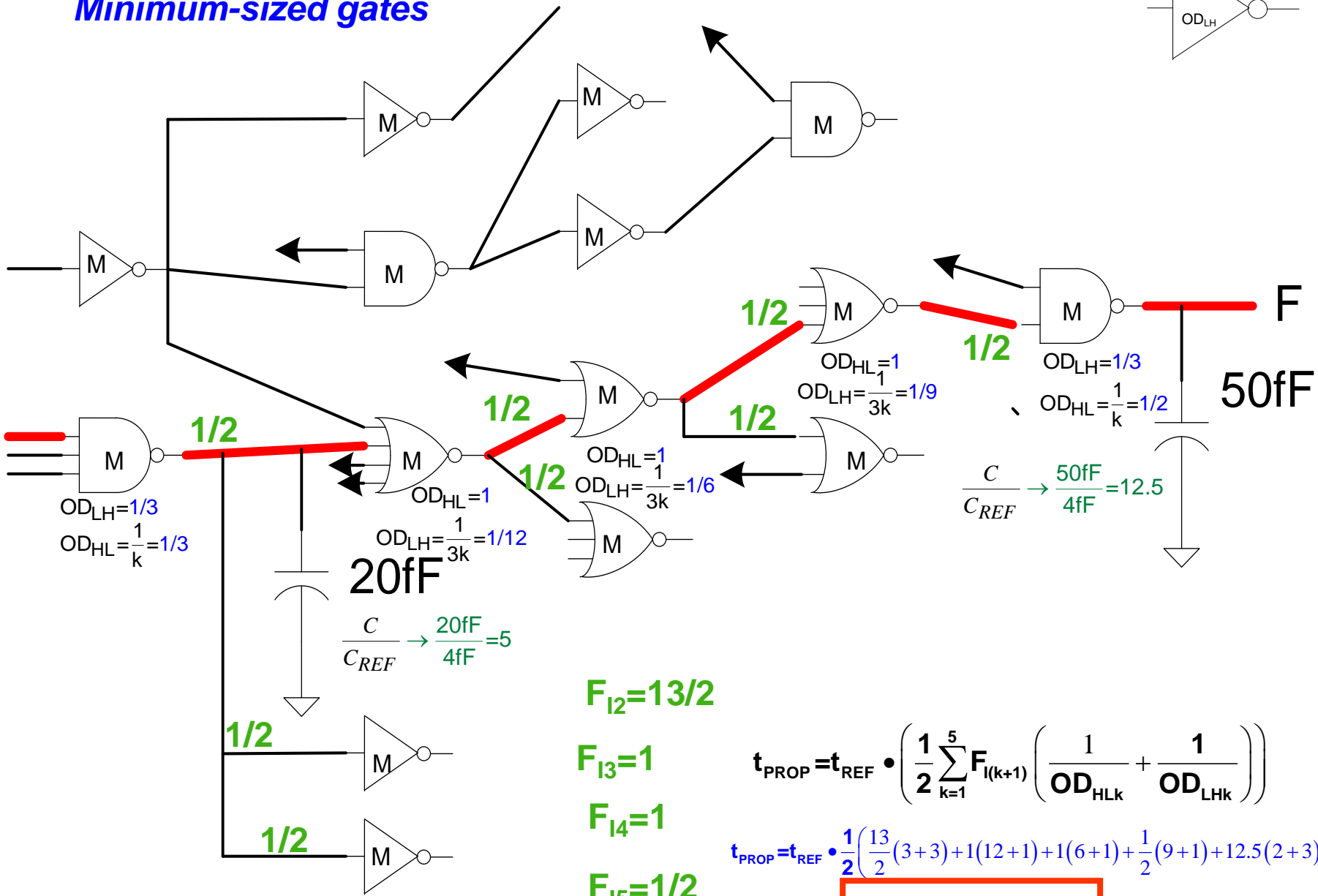
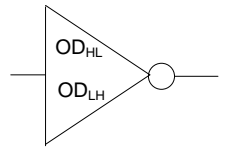

$$t_{PROP} = t_{REF} \cdot \left(\frac{1}{2} \sum_{k=1}^5 F_{l(k+1)} \left(\frac{1}{OD_{HLk}} + \frac{1}{OD_{LHk}} \right) \right)$$

$$t_{PROP} = t_{REF} \cdot \frac{1}{2} \left(\frac{13}{2}(3+3) + 1(12+1) + 1(6+1) + \frac{1}{2}(9+1) + 12.5(2+3) \right)$$

$$t_{PROP} = 63.25 \cdot t_{REF}$$

Propagation Delay in Multiple-Levels of Logic with Stage Loading

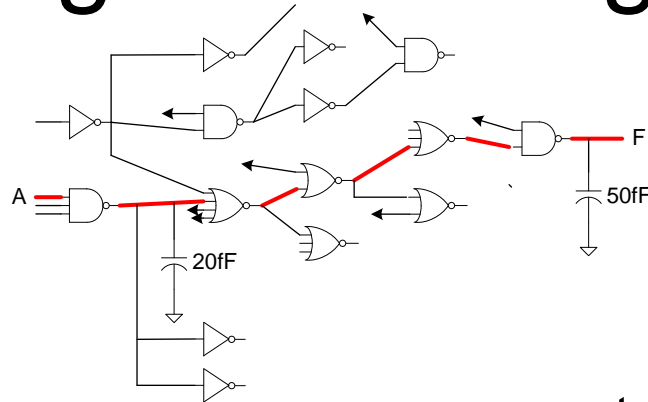

- Equal rise/fall (no overdrive)

$$t_{\text{PROP}} = t_{\text{REF}} \sum_{k=1}^n F_{I_{(k+1)}}$$

- Equal rise/fall with overdrive

$$t_{\text{PROP}} = t_{\text{REF}} \sum_{k=1}^n \frac{F_{I_{(k+1)}}}{\text{OD}_k}$$

- Minimum Sized

$$t_{\text{PROP}} = t_{\text{REF}} \cdot \left(\frac{1}{2} \sum_{k=1}^n F_{I_{(k+1)}} \left(\frac{1}{\text{OD}_{\text{HLk}}} + \frac{1}{\text{OD}_{\text{LHk}}} \right) \right)$$



- Asymmetric Overdrive

$$t_{\text{PROP}} = t_{\text{REF}} \cdot \left(\frac{1}{2} \sum_{k=1}^n F_{I_{(k+1)}} \left(\frac{1}{\text{OD}_{\text{HLk}}} + \frac{1}{\text{OD}_{\text{LHk}}} \right) \right)$$



- Combination of equal rise/fall, minimum size and overdrive

$$t_{\text{PROP}} = ?$$

Propagation Delay in Multiple-Levels of Logic with Stage Loading

Asymmetric-sized gates

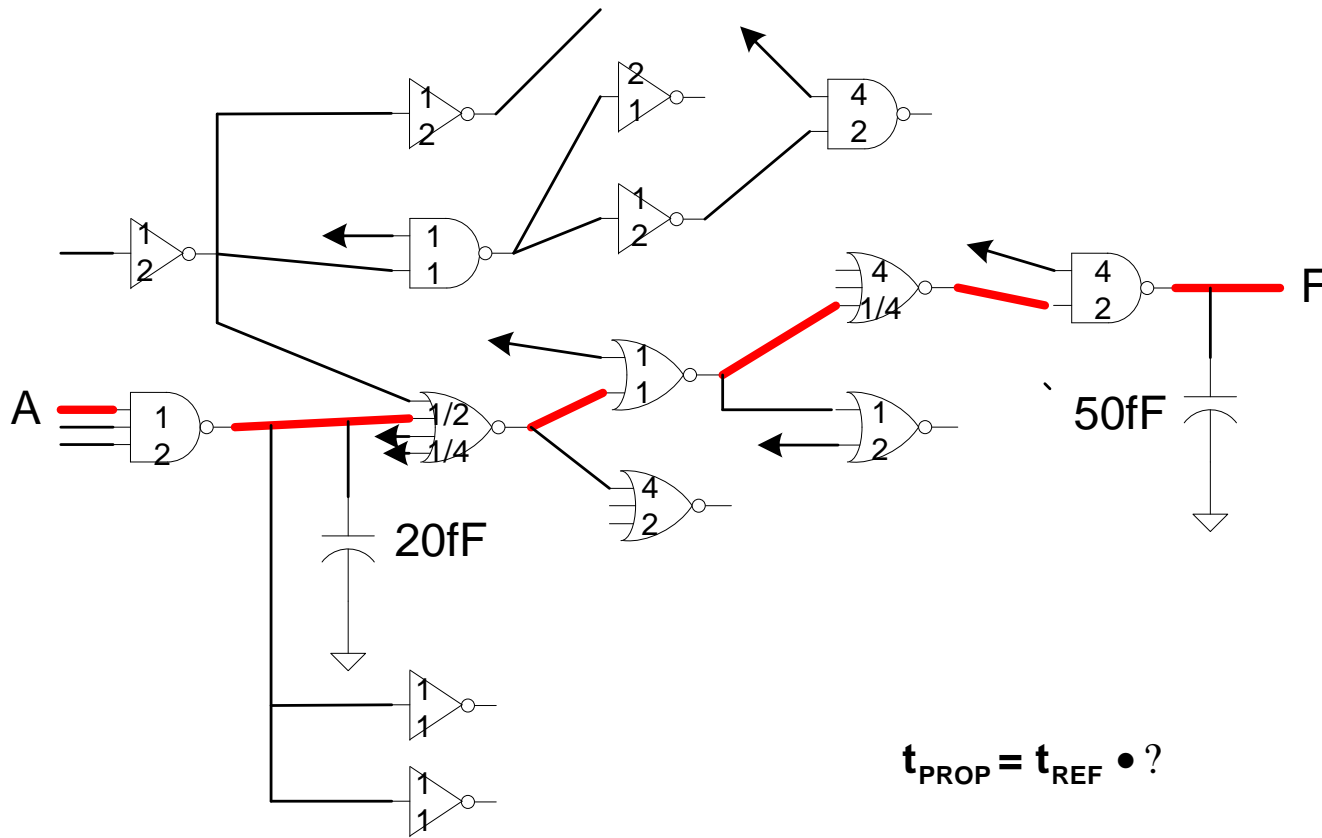

Propagation Delay in Multiple-Levels of Logic with Stage Loading

Asymmetric-sized gates

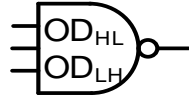

	Equal Rise/Fall	Equal Rise/Fall (with OD)	Minimum Sized	Asymmetric OD (OD _{HL} , OD _{LH})
C_{IN}/C_{REF}				
Inverter	1	OD	1/2	?
NOR	$\frac{3k+1}{4}$	$\frac{3k+1}{4} \cdot OD$	1/2	?
NAND	$\frac{3+k}{4}$	$\frac{3+k}{4} \cdot OD$	1/2	?
Overdrive				
Inverter				
HL	1	OD	1	OD _{HL}
LH	1	OD	1/3	OD _{LH}
NOR				
HL	1	OD	1	OD _{HL}
LH	1	OD	1/(3k)	OD _{LH}
NAND				
HL	1	OD	1/k	OD _{HL}
LH	1	OD	1/3	OD _{LH}
t_{PROP}/t_{REF}	$\sum_{k=1}^n F_{l(k+1)}$	$\sum_{k=1}^n \frac{F_{l(k+1)}}{OD_k}$	$\frac{1}{2} \sum_{k=1}^n F_{l(k+1)} \left(\frac{1}{OD_{HLk}} + \frac{1}{OD_{LHk}} \right)$	$\frac{1}{2} \sum_{k=1}^n F_{l(k+1)} \left(\frac{1}{OD_{HLk}} + \frac{1}{OD_{LHk}} \right)$

$$t_{PROP} = t_{REF} \cdot \left(\frac{1}{2} \sum_{k=1}^n F_{l(k+1)} \left(\frac{1}{OD_{HLk}} + \frac{1}{OD_{LHk}} \right) \right)$$

Asymmetric-sized gates

$$C_{IN}/C_{REF}$$

Inverter

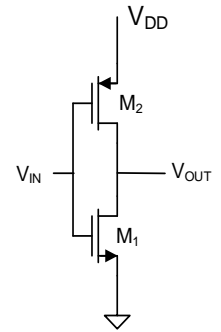

NOR

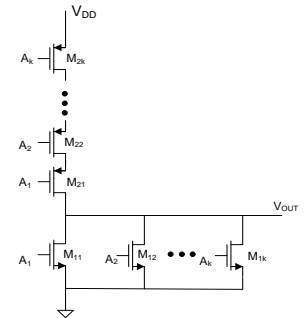

NAND

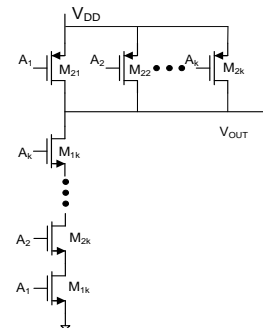

Asymmetric-sized gates

$$C_{IN}/C_{REF}$$

Inverter

$$\frac{C_{IN}}{C_{REF}} = \frac{C_{OX} W_n OD_{HL} L + C_{OX} (3W_n) OD_{LH} L}{4C_{OX} W_n L} = \frac{OD_{HL} + 3OD_{LH}}{4}$$

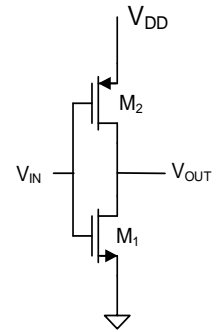

NOR

$$\frac{C_{IN}}{C_{REF}} = \frac{C_{OX} W_n OD_{HL} L + C_{OX} (3kW_n) OD_{LH} L}{4C_{OX} W_n L} = \frac{OD_{HL} + 3kOD_{LH}}{4}$$

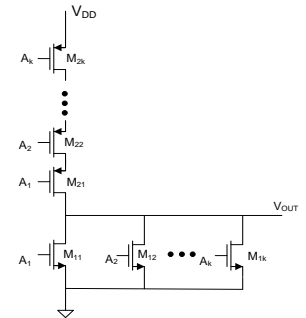

NAND

$$\frac{C_{IN}}{C_{REF}} = \frac{C_{OX} kW_n OD_{HL} L + C_{OX} (3W_n) OD_{LH} L}{4C_{OX} W_n L} = \frac{k \cdot OD_{HL} + 3OD_{LH}}{4}$$

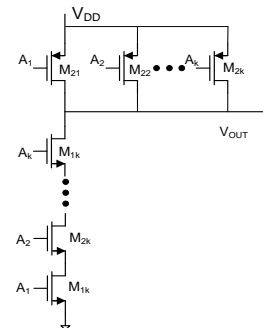

Propagation Delay in Multiple-Levels of Logic with Stage Loading

Asymmetric-sized gates

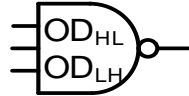

	Equal Rise/Fall	Equal Rise/Fall (with OD)	Minimum Sized	Asymmetric OD (OD _{HL} , OD _{LH})
C_{IN}/C_{REF}				
Inverter	1	OD	1/2	$\frac{OD_{HL} + 3 \cdot OD_{LH}}{4}$
NOR	$\frac{3k+1}{4}$	$\frac{3k+1}{4} \cdot OD$	1/2	$\frac{OD_{HL} + 3k \cdot OD_{LH}}{4}$
NAND	$\frac{3+k}{4}$	$\frac{3+k}{4} \cdot OD$	1/2	$\frac{k \cdot OD_{HL} + 3 \cdot OD_{LH}}{4}$
Overdrive				
Inverter				
HL	1	OD	1	OD _{HL}
LH	1	OD	1/3	OD _{LH}
NOR				
HL	1	OD	1	OD _{HL}
LH	1	OD	1/(3k)	OD _{LH}
NAND				
HL	1	OD	1/k	OD _{HL}
LH	1	OD	1/3	OD _{LH}
t_{PROP}/t_{REF}	$\sum_{k=1}^n F_{l(k+1)}$	$\sum_{k=1}^n \frac{F_{l(k+1)}}{OD_k}$	$\frac{1}{2} \sum_{k=1}^n F_{l(k+1)} \left(\frac{1}{OD_{HLk}} + \frac{1}{OD_{LHk}} \right)$	$\frac{1}{2} \sum_{k=1}^n F_{l(k+1)} \left(\frac{1}{OD_{HLk}} + \frac{1}{OD_{LHk}} \right)$

$$t_{PROP} = t_{REF} \cdot \left(\frac{1}{2} \sum_{k=1}^n F_{l(k+1)} \left(\frac{1}{OD_{HLk}} + \frac{1}{OD_{LHk}} \right) \right)$$

Propagation Delay in Multiple-Levels of Logic with Stage Loading

Asymmetric-sized gates

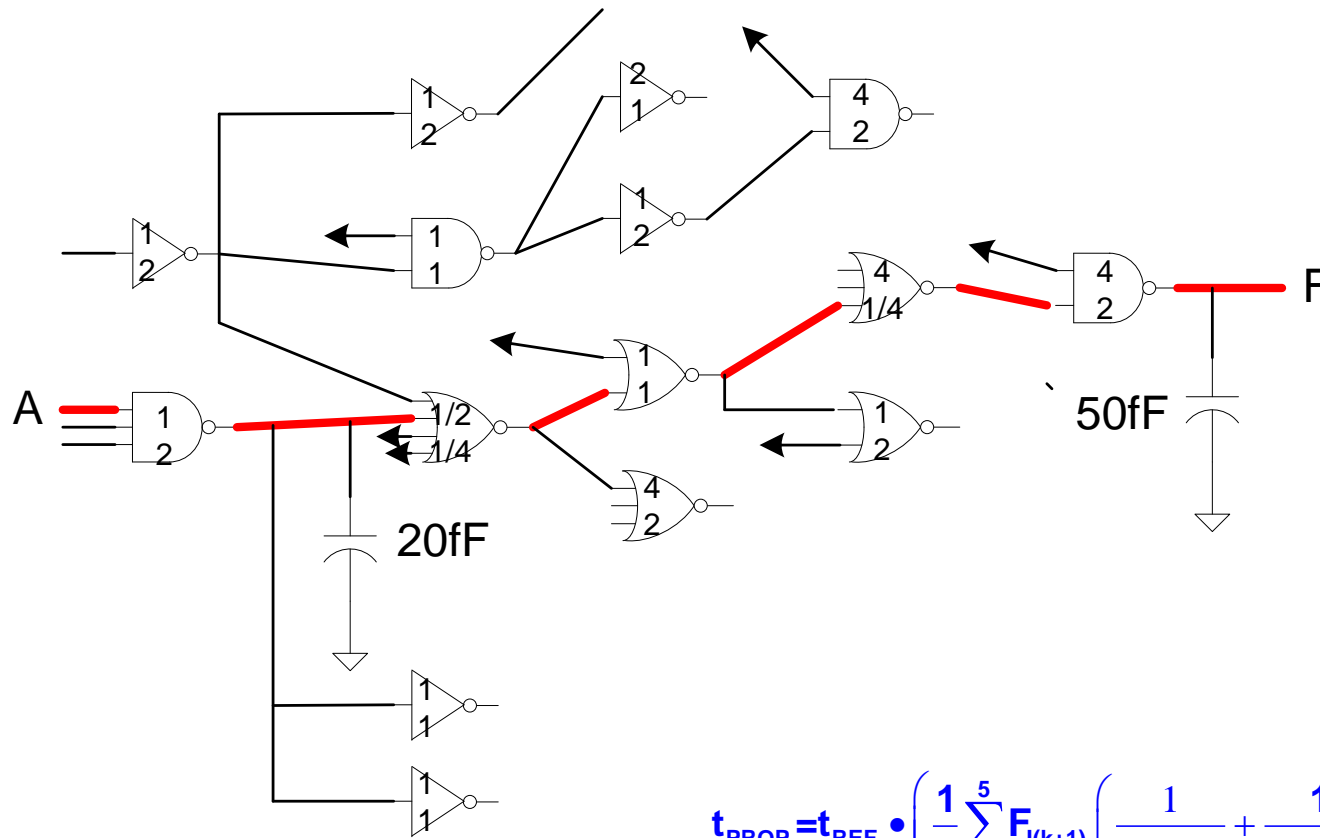

$$t_{\text{PROP}} = t_{\text{REF}} \cdot \left(\frac{1}{2} \sum_{k=1}^5 F_{l(k+1)} \left(\frac{1}{\text{OD}_{\text{HLk}}} + \frac{1}{\text{OD}_{\text{LHK}}} \right) \right)$$

Asymmetric-sized gates

(Note: This C_{OX} is somewhat larger than that in the 0.5u ON process)

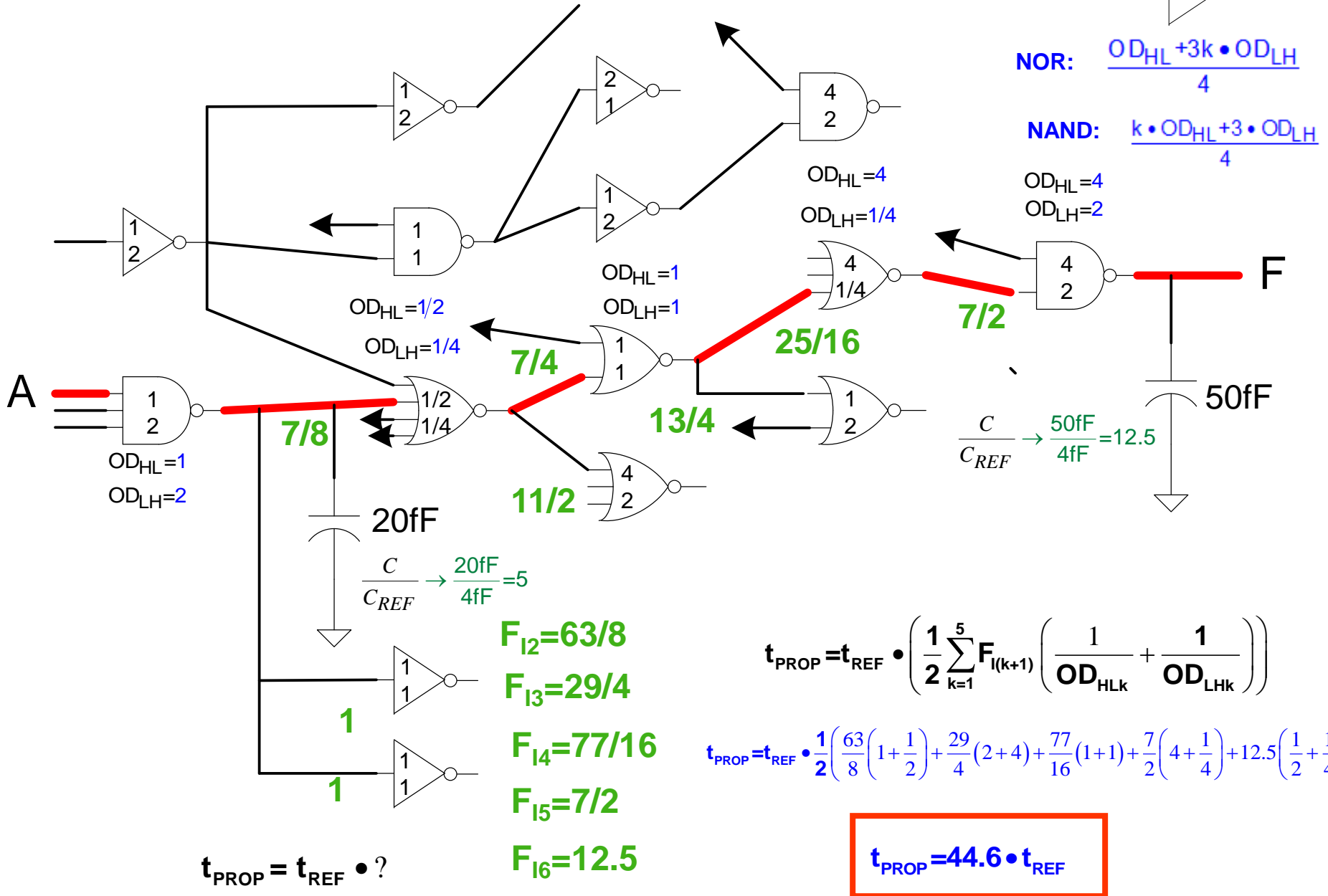
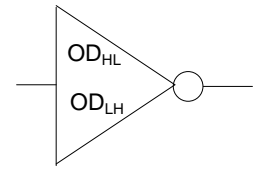

$t_{PROP} = t_{REF} \cdot ?$

$F_{12} = 63/8$

$F_{13} = 29/4$

$F_{14} = 77/16$

$F_{15} = 7/2$

$F_{16} = 12.5$

$$t_{PROP} = t_{REF} \cdot \left(\frac{1}{2} \sum_{k=1}^5 F_{I(k+1)} \left(\frac{1}{OD_{HLk}} + \frac{1}{OD_{LHk}} \right) \right)$$

$$t_{PROP} = t_{REF} \cdot \frac{1}{2} \left(\frac{63}{8} \left(1 + \frac{1}{2} \right) + \frac{29}{4} (2+4) + \frac{77}{16} (1+1) + \frac{7}{2} \left(4 + \frac{1}{4} \right) + 12.5 \left(\frac{1}{2} + \frac{1}{4} \right) \right)$$

$t_{PROP} = 44.6 \cdot t_{REF}$

Propagation Delay in Multiple-Levels of Logic with Stage Loading

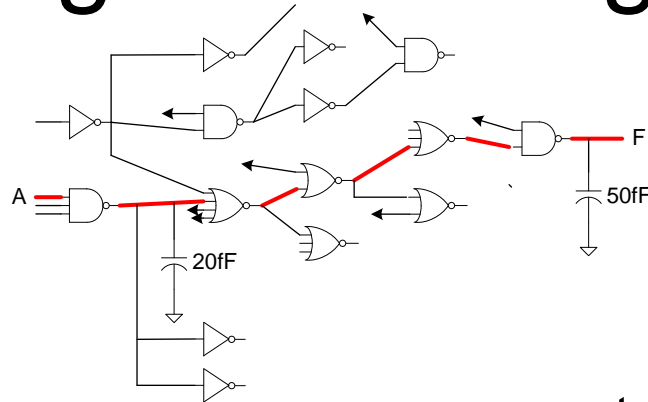

- Equal rise/fall (no overdrive)

$$t_{\text{PROP}} = t_{\text{REF}} \sum_{k=1}^n F_{I_{(k+1)}}$$

- Equal rise/fall with overdrive

$$t_{\text{PROP}} = t_{\text{REF}} \sum_{k=1}^n \frac{F_{I_{(k+1)}}}{\text{OD}_k}$$

- Minimum Sized

$$t_{\text{PROP}} = t_{\text{REF}} \cdot \left(\frac{1}{2} \sum_{k=1}^n F_{I_{(k+1)}} \left(\frac{1}{\text{OD}_{\text{HLk}}} + \frac{1}{\text{OD}_{\text{LHk}}} \right) \right)$$

- Asymmetric Overdrive

$$t_{\text{PROP}} = t_{\text{REF}} \cdot \left(\frac{1}{2} \sum_{k=1}^n F_{I_{(k+1)}} \left(\frac{1}{\text{OD}_{\text{HLk}}} + \frac{1}{\text{OD}_{\text{LHk}}} \right) \right)$$

- ➔ • Combination of equal rise/fall, minimum size and overdrive

$$t_{\text{PROP}} = ?$$

Propagation Delay in Multiple-Levels of Logic with Stage Loading

Mixture of Minimum-sized gates, equal rise/fall times and OD

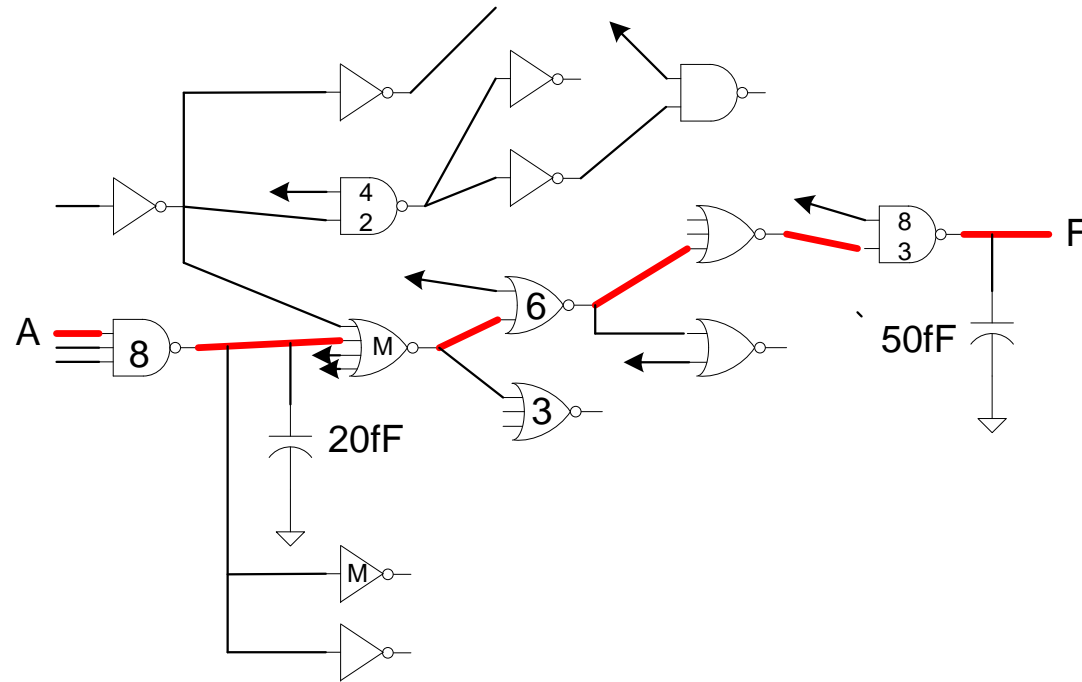

$$t_{\text{PROP}} = t_{\text{REF}} \bullet ?$$

Driving Notation

- **Equal rise/fall (no overdrive)**



- **Equal rise/fall with overdrive**



- **Minimum Sized**



- **Asymmetric Overdrive**

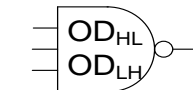

Propagation Delay in Multiple-Levels of Logic with Stage Loading

Mixture of Minimum-sized gates, equal rise/fall gates and OD

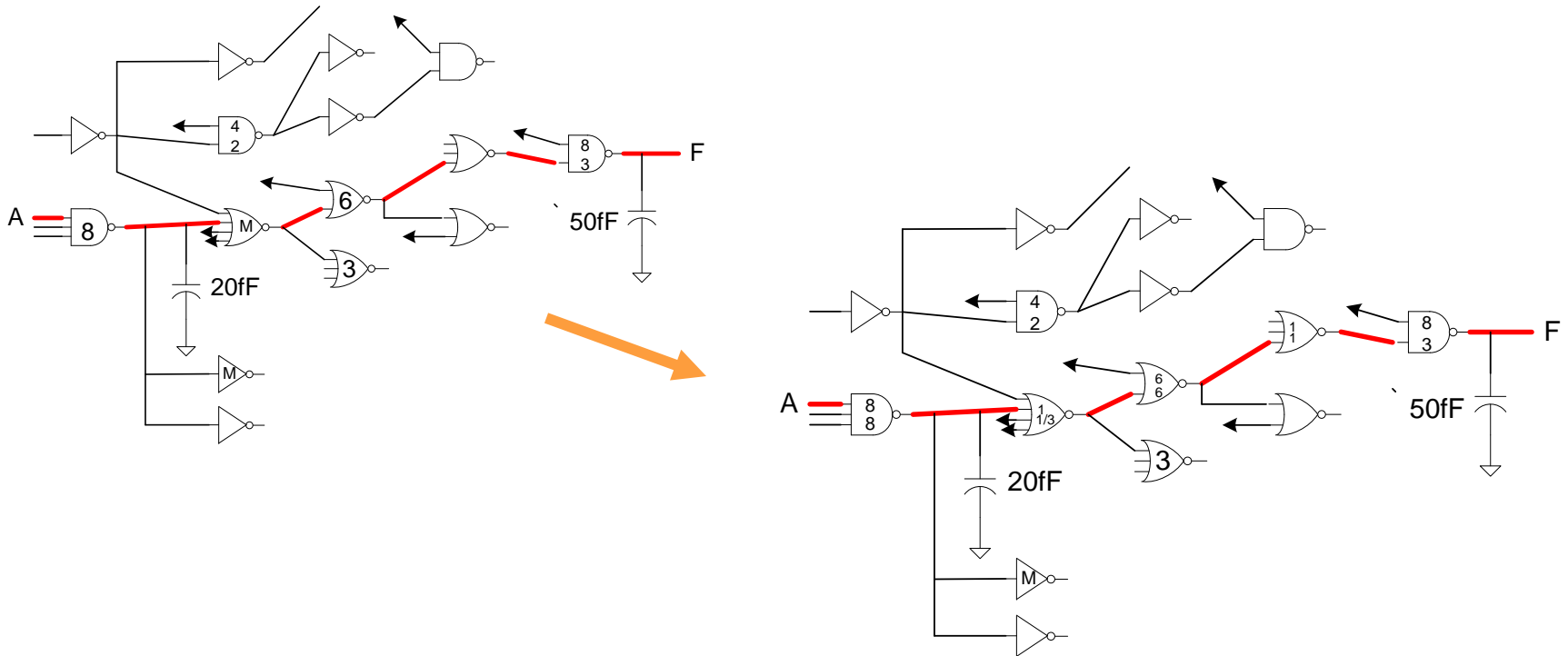

$$t_{\text{PROP}} = t_{\text{REF}} \cdot \left(\frac{1}{2} \sum_{k=1}^5 F_{l(k+1)} \left(\frac{1}{\text{OD}_{\text{HLk}}} + \frac{1}{\text{OD}_{\text{LHk}}} \right) \right)$$

Propagation Delay in Multiple-Levels of Logic with Stage Loading

Mixture of Minimum-sized gates, equal rise/fall gates and OD

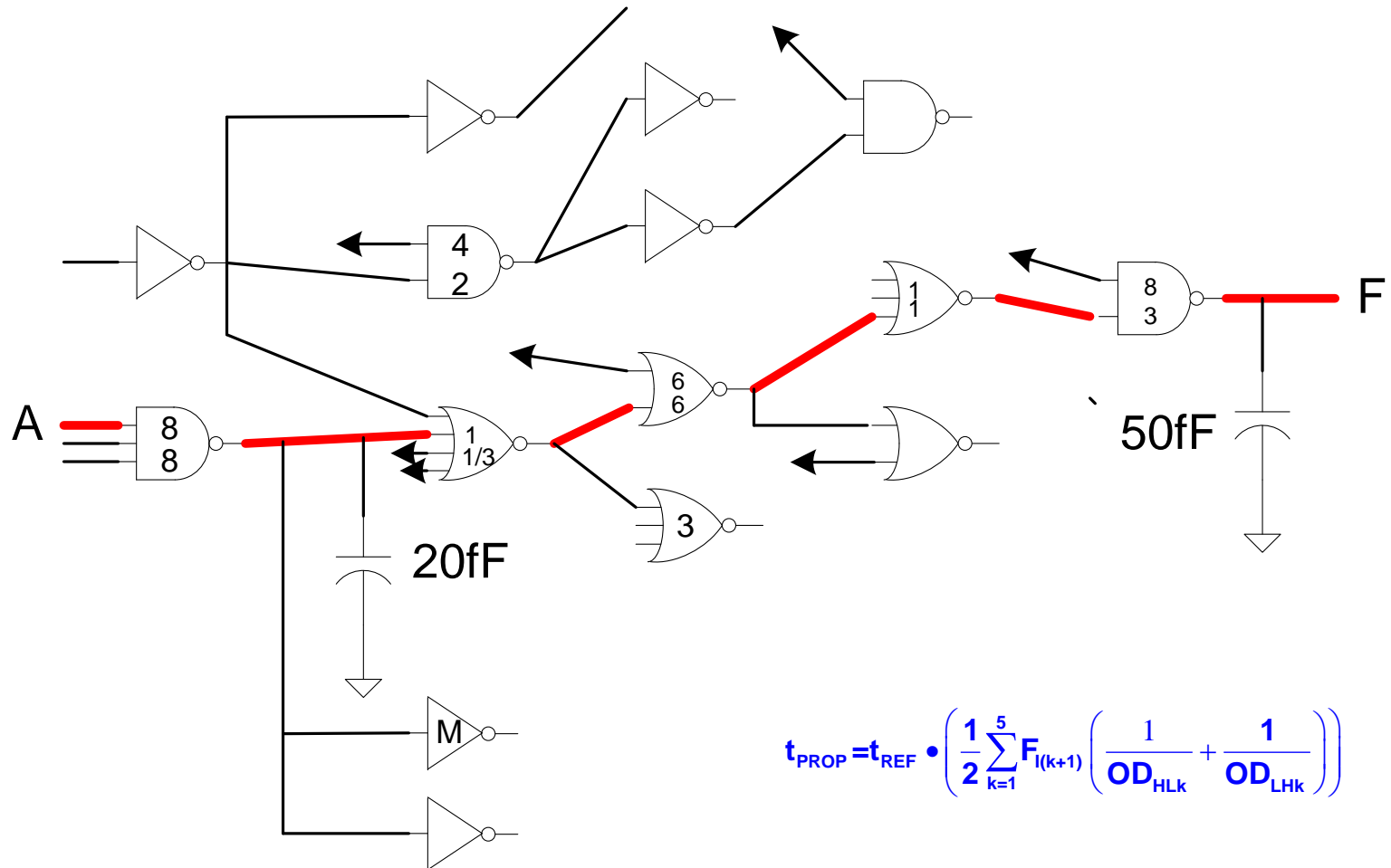

$$t_{\text{PROP}} = t_{\text{REF}} \cdot \left(\frac{1}{2} \sum_{k=1}^5 F_{l(k+1)} \left(\frac{1}{OD_{\text{HLk}}} + \frac{1}{OD_{\text{LHk}}} \right) \right)$$

Propagation Delay in Multiple-Levels of Logic with Stage Loading

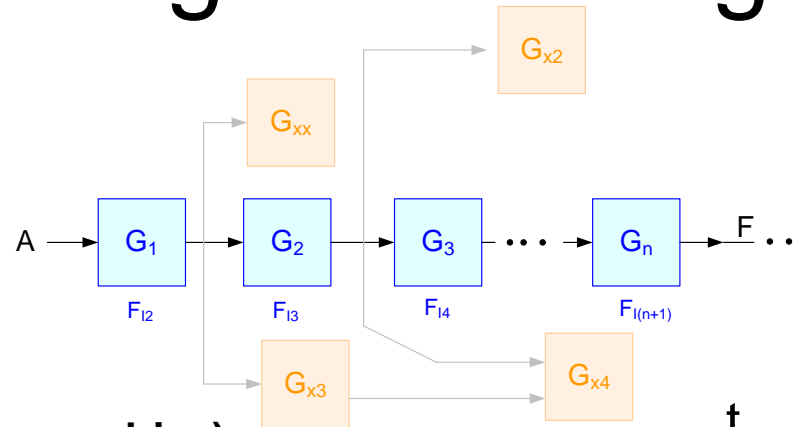

- Equal rise/fall (no overdrive)

$$t_{\text{PROP}} = t_{\text{REF}} \sum_{k=1}^n F_{I(k+1)}$$

- Equal rise/fall with overdrive

$$t_{\text{PROP}} = t_{\text{REF}} \sum_{k=1}^n \frac{F_{I(k+1)}}{\text{OD}_k}$$

- Minimum Sized

$$t_{\text{PROP}} = t_{\text{REF}} \cdot \left(\frac{1}{2} \sum_{k=1}^n F_{I(k+1)} \left(\frac{1}{\text{OD}_{\text{HLk}}} + \frac{1}{\text{OD}_{\text{LHk}}} \right) \right)$$



- Asymmetric overdrive

$$t_{\text{PROP}} = t_{\text{REF}} \cdot \left(\frac{1}{2} \sum_{k=1}^n F_{I(k+1)} \left(\frac{1}{\text{OD}_{\text{HLk}}} + \frac{1}{\text{OD}_{\text{LHk}}} \right) \right)$$

- Combination of equal rise/fall, minimum size and overdrive

$$t_{\text{PROP}} = t_{\text{REF}} \cdot \left(\frac{1}{2} \sum_{k=1}^n F_{I(k+1)} \left(\frac{1}{\text{OD}_{\text{HLk}}} + \frac{1}{\text{OD}_{\text{LHk}}} \right) \right)$$

Summary: Propagation Delay in Multiple-Levels of Logic with Stage Loading

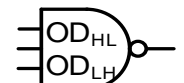
				
	Equal Rise/Fall	Equal Rise/Fall (with OD)	Minimum Sized	Asymmetric OD (OD _{HL} , OD _{LH})
C_{IN}/C_{REF}				
Inverter	1	OD	1/2	$\frac{OD_{HL} + 3 \cdot OD_{LH}}{4}$
NOR	$\frac{3k+1}{4}$	$\frac{3k+1}{4} \cdot OD$	1/2	$\frac{OD_{HL} + 3k \cdot OD_{LH}}{4}$
NAND	$\frac{3+k}{4}$	$\frac{3+k}{4} \cdot OD$	1/2	$\frac{k \cdot OD_{HL} + 3 \cdot OD_{LH}}{4}$
Overdrive				
Inverter				
HL	1	OD	1	OD _{HL}
LH	1	OD	1/3	OD _{LH}
NOR				
HL	1	OD	1	OD _{HL}
LH	1	OD	1/(3k)	OD _{LH}
NAND				
HL	1	OD	1/k	OD _{HL}
LH	1	OD	1/3	OD _{LH}
t_{PROP}/t_{REF}	$\sum_{k=1}^n F_{I(k+1)}$	$\sum_{k=1}^n \frac{F_{I(k+1)}}{OD_k}$	$\frac{1}{2} \sum_{k=1}^n F_{I(k+1)} \left(\frac{1}{OD_{HLk}} + \frac{1}{OD_{LHk}} \right)$	$\frac{1}{2} \sum_{k=1}^n F_{I(k+1)} \left(\frac{1}{OD_{HLk}} + \frac{1}{OD_{LHk}} \right)$

Digital Circuit Design

- Hierarchical Design
- Basic Logic Gates
- Properties of Logic Families
- Characterization of CMOS Inverter
- Static CMOS Logic Gates
 - Ratio Logic
- Propagation Delay
 - Simple analytical models
 - FI/OD
 - Logical Effort
 - Elmore Delay
- Sizing of Gates
 - The Reference Inverter

- Propagation Delay with Multiple Levels of Logic
- Optimal driving of Large Capacitive Loads
- Power Dissipation in Logic Circuits
 - Other Logic Styles
 - Array Logic
 - Ring Oscillators

→ **done**

→ **partial**

Driving Large Capacitive Loads

Example

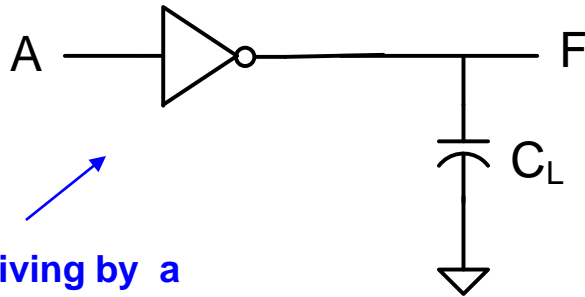

Assume $C_L = 1000C_{REF}$

Assume driving by a reference inverter

$t_{PROP}=?$

In 0.5u proc $t_{REF}=20ps$,
 $C_{REF}=4fF, R_{PDREF}=2.5K$

Driving Large Capacitive Loads

Example

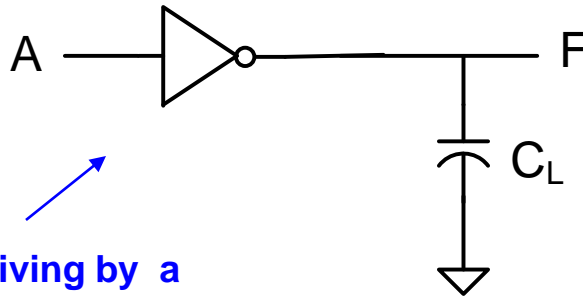

Assume $C_L = 1000C_{REF}$

Assume driving by a reference inverter

$$t_{PROP} = 1000t_{REF}$$

t_{PROP} is too long !

In 0.5u proc $t_{REF} = 20ps$,
 $C_{REF} = 4fF, R_{PDREF} = 2.5K$

Driving Large Capacitive Loads

Example

Assume $C_L = 1000C_{REF}$

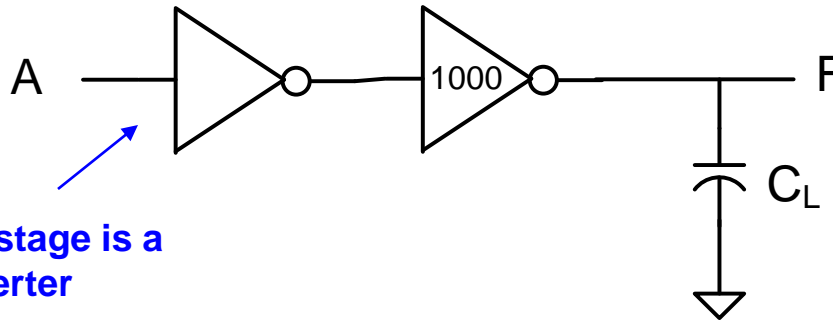

Assume first stage is a reference inverter

$$t_{PROP} = ?$$

$$t_{PROP} = t_{REF} \sum_{k=1}^2 \frac{F_{I(k+1)}}{OD_k}$$

$$t_{PROP} = t_{REF} \left(\frac{1}{1} 1000 + \frac{1}{1000} 1000 \right) = t_{REF} (1000 + 1)$$

$$t_{PROP} = t_{REF} (1001)$$

Delay of second inverter is really small but overall delay is even longer than before!

Driving Large Capacitive Loads

Example

Assume $C_L = 1000C_{REF}$

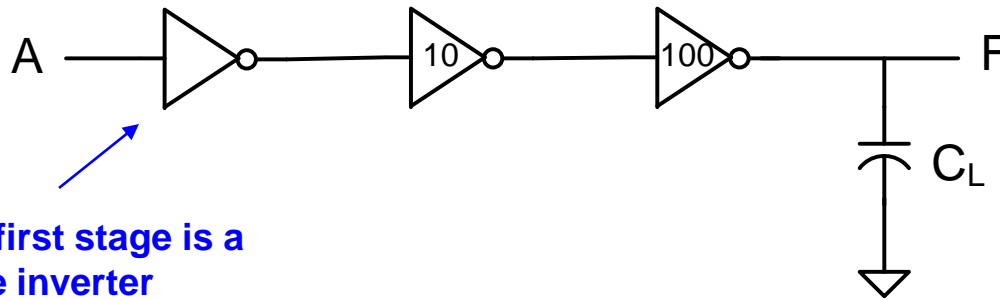

Assume first stage is a reference inverter

$$t_{PROP} = t_{REF} \sum_{k=1}^3 \frac{F_{I(k+1)}}{OD_k}$$

$$t_{PROP} = t_{REF} \left(\frac{1}{1} 10 + \frac{1}{10} 100 + \frac{1}{100} 1000 \right) = t_{REF} (10 + 10 + 10)$$

$$t_{PROP} = 30t_{REF}$$

Dramatic reduction in propagation delay (over a factor of 30!)

What is the fastest way to drive a large capacitive load?

Optimal Driving of Capacitive Loads

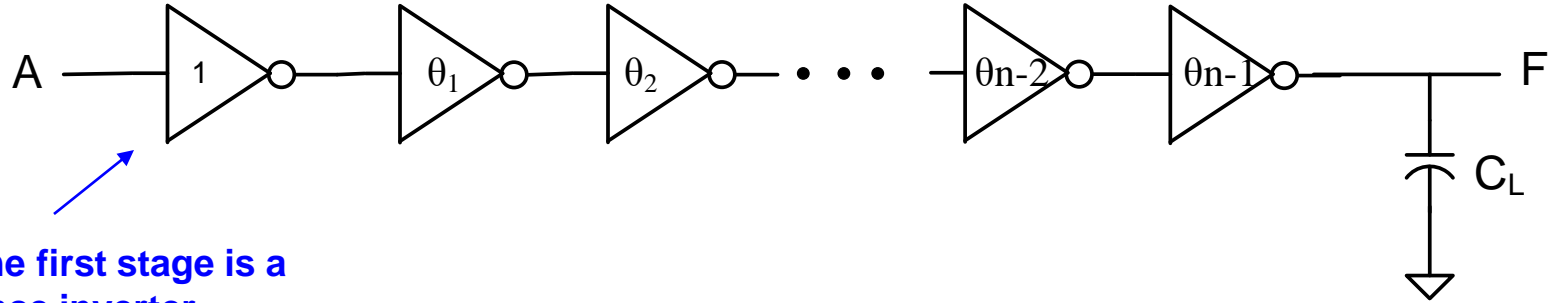

Assume first stage is a reference inverter

Need to determine the number of stages, n , and the OD factors for each stage to minimize t_{PROP}

$$t_{\text{PROP}} = t_{\text{REF}} \sum_{k=1}^n \frac{F_{l(k+1)}}{\text{OD}_k} \longrightarrow t_{\text{PROP}} = t_{\text{REF}} \sum_{k=1}^n \frac{\theta_k}{\theta_{k-1}}$$

$$\text{where } \theta_0 = 1, \theta_n = C_L / C_{\text{REF}}$$

This becomes an n -parameter optimization (minimization) problem !

Unknown parameters: $\{\theta_1, \theta_2, \dots, \theta_{n-1}, n\}$

An n -parameter nonlinear optimization problem is generally difficult !!!!

Optimal Driving of Capacitive Loads

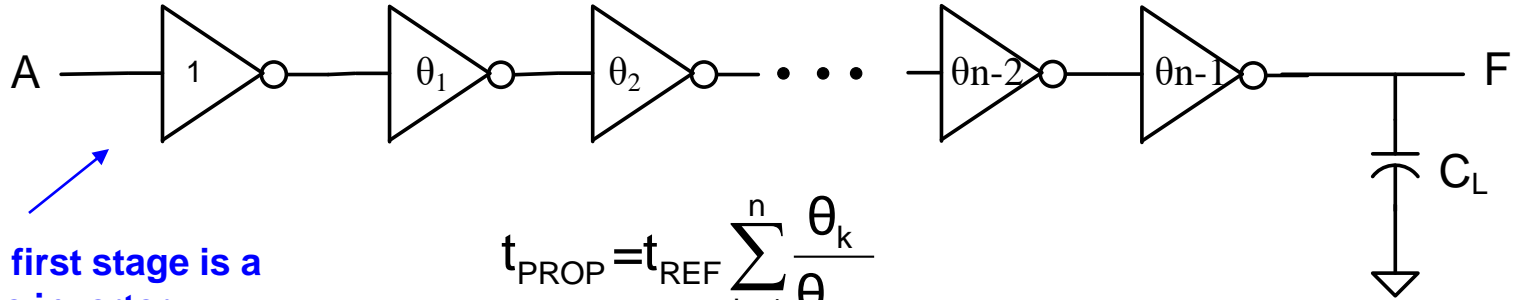

$$t_{\text{PROP}} = t_{\text{REF}} \sum_{k=1}^n \frac{\theta_k}{\theta_{k-1}}$$

Order reduction strategy : Assume overdrive of stages increases by the same factor clear until the load

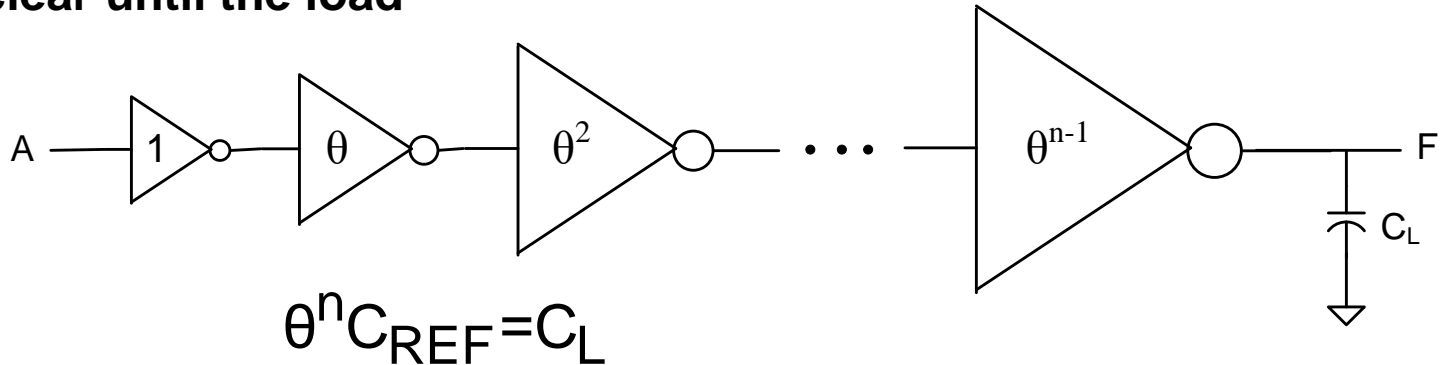

This becomes a 2-parameter optimization (minimization) problem !

Unknown parameters: $\{\theta, n\}$

One constraint : $\theta^n C_{\text{REF}} = C_L$



One degree of freedom

Optimal Driving of Capacitive Loads

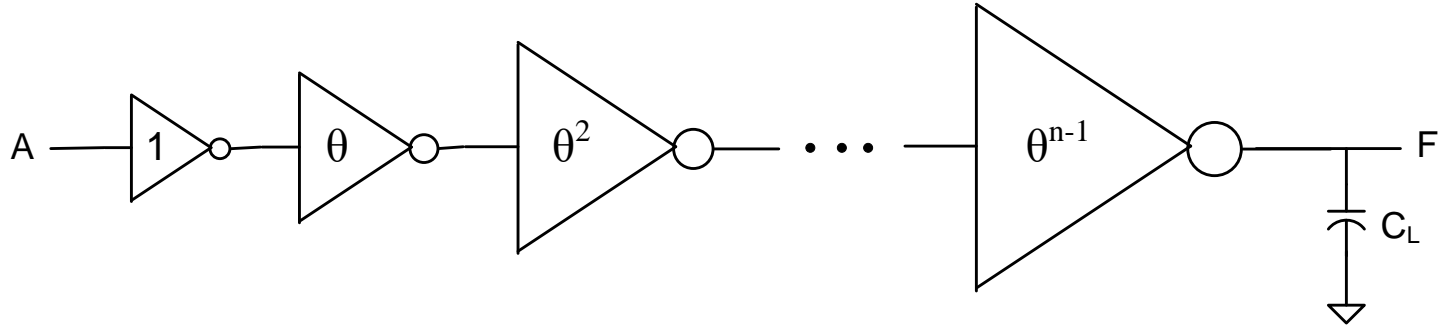

$$t_{\text{PROP}} = t_{\text{REF}} \sum_{k=1}^n \frac{\theta_k}{\theta_{k-1}}$$



$$t_{\text{PROP}} = t_{\text{REF}} \sum_{k=1}^n \frac{\theta^k}{\theta^{k-1}}$$

$$t_{\text{PROP}} = t_{\text{REF}} n\theta$$

$$\theta^n C_{\text{REF}} = C_L$$

or

$$F|_L = \theta^n$$

$$\left. \begin{array}{l} t_{\text{PROP}} = t_{\text{REF}} n\theta \\ \theta^n C_{\text{REF}} = C_L \end{array} \right\}$$

Unknown parameters: $\{\theta, n\}$

$$\theta^n C_{\text{REF}} = C_L \longrightarrow n = \frac{1}{\ln(\theta)} \ln\left(\frac{C_L}{C_{\text{REF}}}\right)$$

Thus obtain an expression for t_{PROP} in terms of only θ

$$t_{\text{PROP}} = t_{\text{REF}} \frac{\theta}{\ln(\theta)} \left[\ln \frac{C_L}{C_{\text{REF}}} \right]$$

Optimal Driving of Capacitive Loads

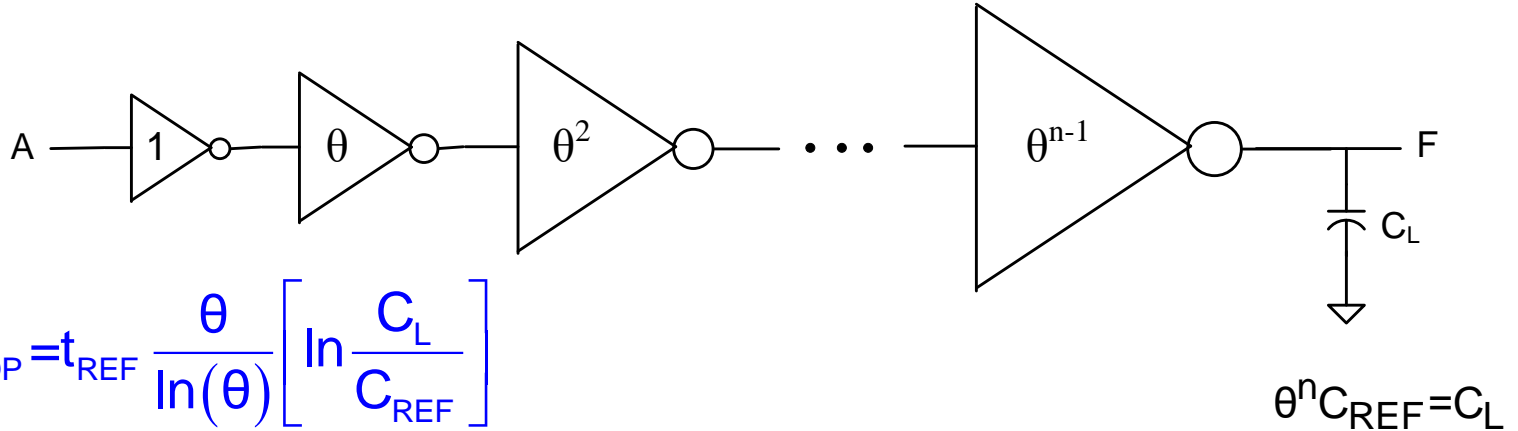

$$t_{PROP} = t_{REF} \frac{\theta}{\ln(\theta)} \left[\ln \frac{C_L}{C_{REF}} \right]$$

It suffices to minimize the function $f(\theta) = \frac{\theta}{\ln(\theta)}$

$$\frac{df}{d\theta} = \frac{\ln(\theta) - \theta \cdot \left(\frac{1}{\theta} \right)}{(\ln(\theta))^2} = 0$$

$$\ln(\theta) - 1 = 0 \quad \rightarrow \quad \theta = e$$

$$n = \frac{1}{\ln(\theta)} \ln \left(\frac{C_L}{C_{REF}} \right) \quad \rightarrow \quad n = \ln \left(\frac{C_L}{C_{REF}} \right) = \ln(FI_L)$$

Optimal Driving of Capacitive Loads

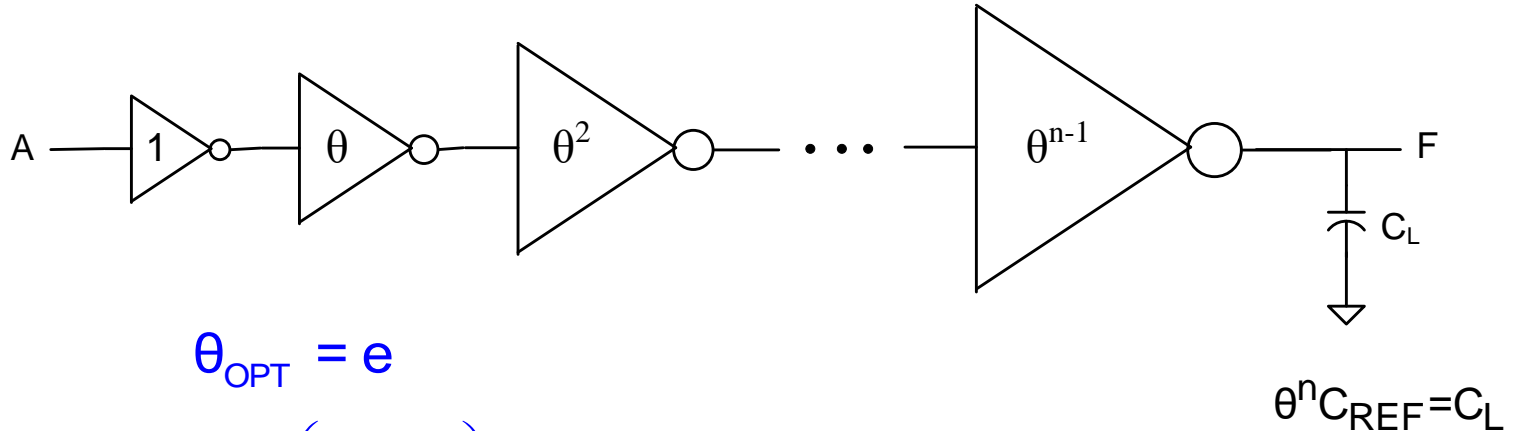

$$\theta_{OPT} = e$$

$$n_{OPT} = \ln\left(\frac{C_L}{C_{REF}}\right) = \ln(FI_L)$$

$$t_{PROP} = t_{REF} \frac{\theta}{\ln(\theta)} \left[\ln \frac{C_L}{C_{REF}} \right]$$

$$t_{PROP} = t_{REF} e \left[\ln \frac{C_L}{C_{REF}} \right] = n\theta t_{REF}$$

Optimal Driving of Capacitive Loads

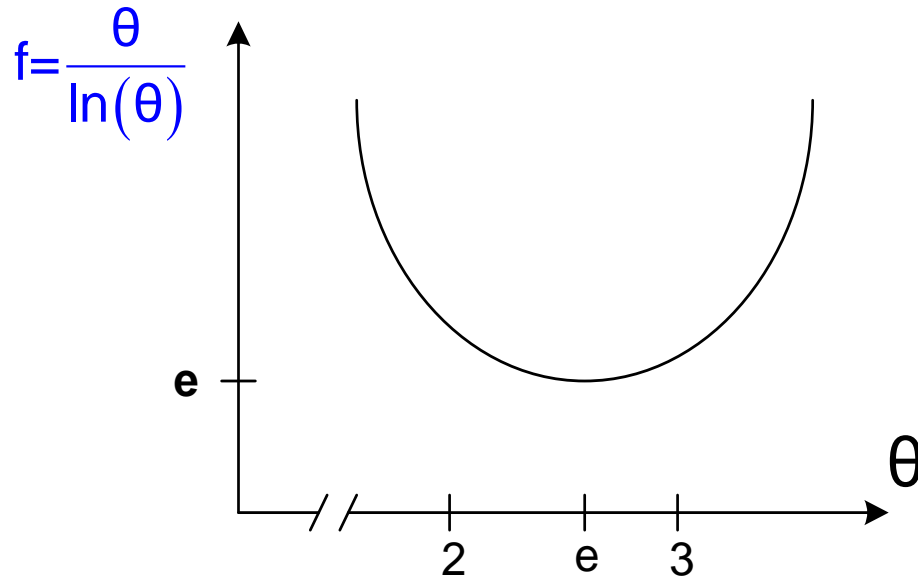

- minimum at $\theta=e$ but shallow inflection point for $2<\theta<3$
- practically pick $\theta=2$, $\theta=2.5$, or $\theta=3$
- since optimization may provide non-integer for n , must pick close integer

Optimal Driving of Capacitive Loads

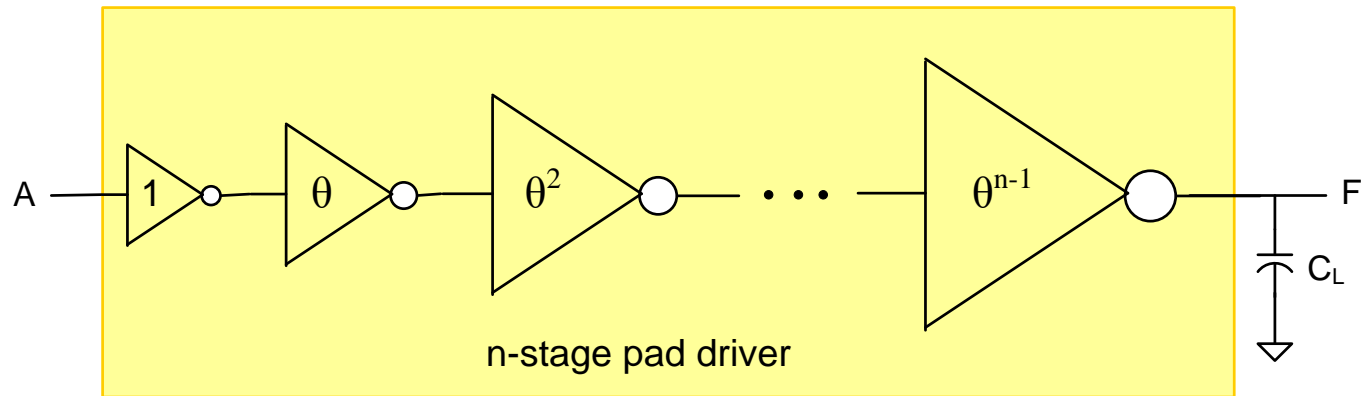

- Often termed a pad driver
- Often used to drive large internal busses as well
- Generally included in standard cells or in cell library
- Device sizes can become very large
- Odd number of stages will cause signal inversion but usually not a problem

Optimal Driving of Capacitive Loads

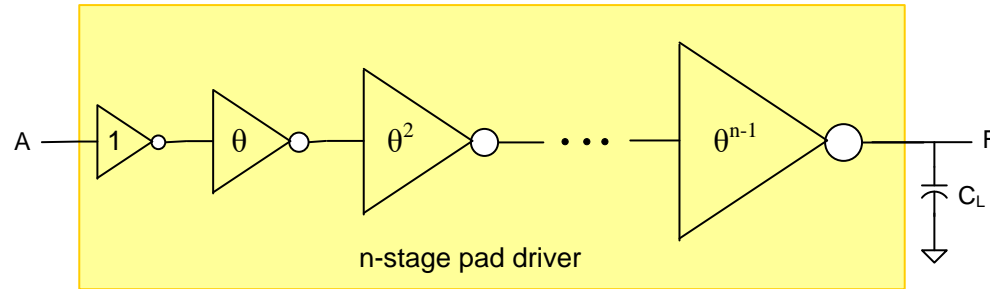

Example: Design a pad driver for driving a load capacitance of 10pF with equal rise/fall times, determine t_{PROP} for the pad driver, and compare this with the propagation delay for driving the pad with a minimum-sized reference inverter.

In 0.5u proc $t_{REF}=20ps$,
 $C_{REF}=4fF, R_{PDREF}=2.5K$

$F_{I_L}=2500$

$$n_{OPT} = \ln\left(\frac{C_L}{C_{REF}}\right) = \ln\left(\frac{10pF}{4fF}\right) = \ln(2500) = 7.8$$

Select $n=8, \theta=2.5$

$$W_{nk} = 2.5^{k-1} \cdot W_{REF}, \quad W_{pk} = 3 \cdot 2.5^{k-1} \cdot W_{REF}$$

Optimal Driving of Capacitive Loads

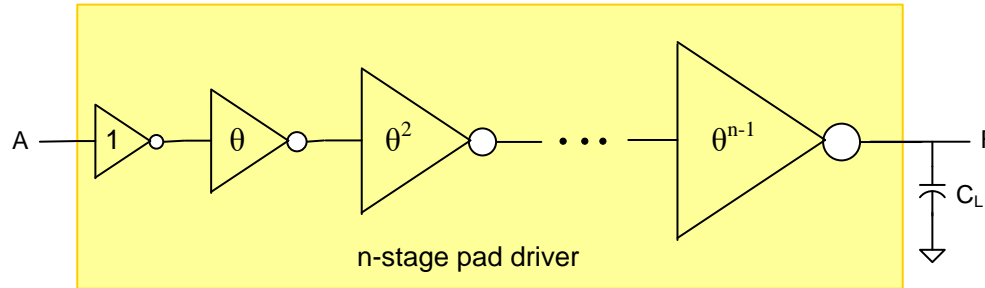

Example: Design a pad driver for driving a load capacitance of 10pF with equal rise/fall times, determine t_{PROP} for the pad driver, and compare this with the propagation delay for driving the pad with a minimum-sized reference inverter.

In 0.5u proc $t_{REF}=20ps$,
 $C_{REF}=4fF, R_{PDREF}=2.5K$

For $\theta = 2.5$, $n=8$ $W_{REF}=W_{MIN}$
 $W_{nk}=2.5^{k-1} \cdot W_{REF}$, $W_{pk} = 3 \cdot 2.5^{k-1} \cdot W_{REF}$

$$L_n = L_p = L_{MIN}$$

k	n-channel	p-channel
1	1 W_{MIN}	3 W_{MIN}
2	2.5 W_{MIN}	7.5 W_{MIN}
3	6.25 W_{MIN}	18.75 W_{MIN}
4	15.6 W_{MIN}	46.9 W_{MIN}
5	39.1 W_{MIN}	117.2 W_{MIN}
6	97.7 W_{MIN}	293.0 W_{MIN}
7	244.1 W_{MIN}	732.4 W_{MIN}
8	610.4 W_{MIN}	1831.1 W_{MIN}

Note devices in last stage are very large !

Optimal Driving of Capacitive Loads

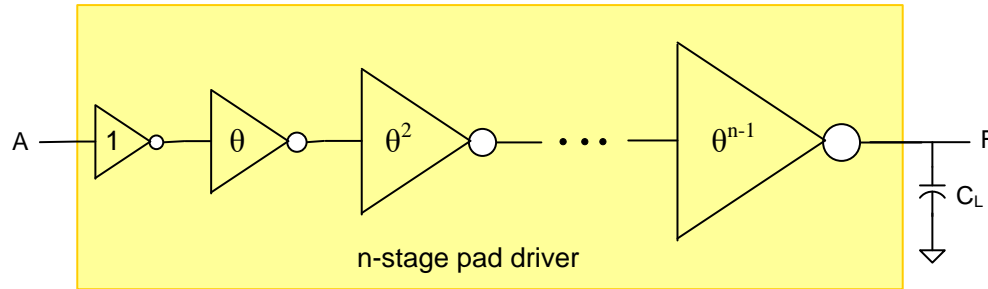

Example: Design a pad driver for driving a load capacitance of 10pF with equal rise/fall times, determine t_{PROP} for the pad driver, and compare this with the propagation delay for driving the pad with a minimum-sized reference inverter.

In 0.5u proc $t_{REF}=20ps$,
 $C_{REF}=4fF, R_{PDREF}=2.5K$

$$W_{nk} = 2.5^{k-1} \cdot W_{REF}, \quad W_{pk} = 3 \cdot 2.5^{k-1} \cdot W_{REF}$$

$$t_{PROP} \cong n\theta t_{REF} = 8 \cdot 2.5 \cdot t_{REF} = 20t_{REF}$$

More accurately:

$$t_{PROP} = t_{REF} \left(\sum_{k=1}^7 \theta + \frac{1}{\theta^7} \frac{C_L}{C_{REF}} \right) = t_{REF} \left(17.5 + \frac{1}{610} 2500 \right) = 21.6t_{REF}$$

Optimal Driving of Capacitive Loads

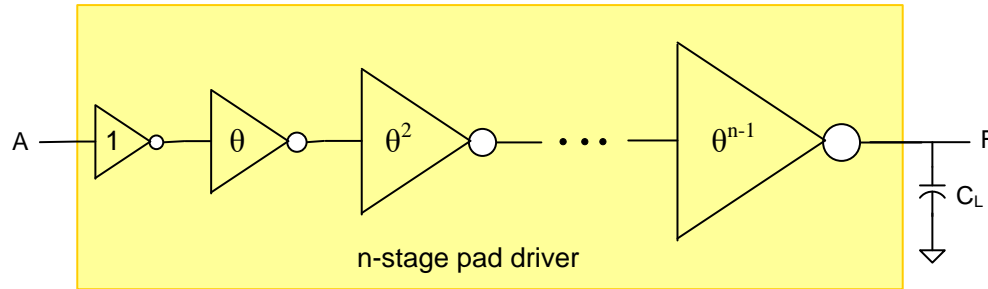

More accurately:

$$t_{\text{PROP}} = t_{\text{REF}} \left(\sum_{k=1}^7 \theta + \frac{1}{\theta^7} \frac{C_L}{C_{\text{REF}}} \right) = t_{\text{REF}} \left(17.5 + \frac{1}{610} 2500 \right) = 21.6 t_{\text{REF}}$$

Possible modest improvement for determining n and theta after determining n_{opt}:

Consider all possible combinations of theta in { 2 , 2.5 , 3} and n in { INT(n_{opt}), 1+INT(n_{opt})}

$$t_{\text{PROP}}(\theta, n) = t_{\text{REF}} \left(\sum_{k=1}^{n-1} \theta + \frac{1}{\theta^{n-1}} \frac{C_L}{C_{\text{REF}}} \right) = t_{\text{REF}} \left((n-1)\theta + \frac{1}{\theta^{n-1}} F_{I_L} \right)$$

Optimal Driving of Capacitive Loads

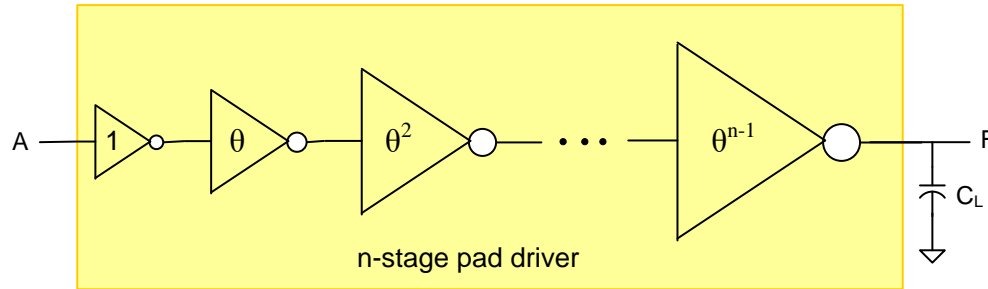

Example: Design a pad driver for driving a load capacitance of 10pF with equal rise/fall times, determine t_{PROP} for the pad driver, and compare this with the propagation delay for driving the pad with a minimum-sized reference inverter.

In 0.5u proc $t_{REF}=20ps$,
 $C_{REF}=4fF, R_{PDREF}=2.5K$

$$W_{nk} = 2.5^{k-1} \cdot W_{REF}, \quad W_{pk} = 3 \cdot 2.5^{k-1} \cdot W_{REF}$$

If driven directly with the minimum-sized reference inverter

$$t_{PROP} = t_{REF} \frac{C_L}{C_{REF}} = 2500 t_{REF}$$

Note an improvement in speed by a factor of approximately

$$r = \frac{2500}{20} = 125$$

Pad Driver Size Implications

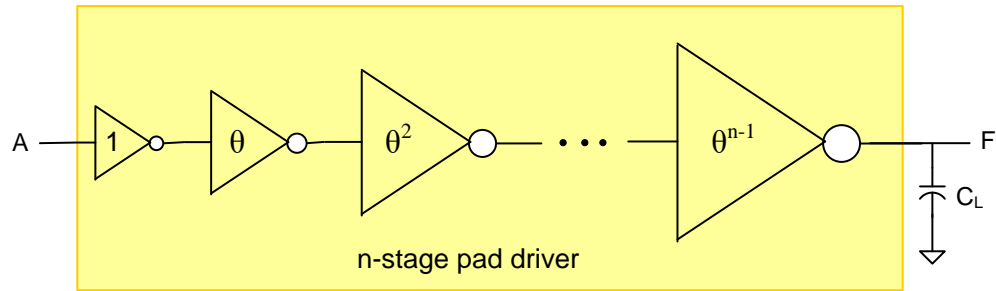

Consider a 7-stage pad driver and assume $\theta = 3$

 : Area of Ref Inverter

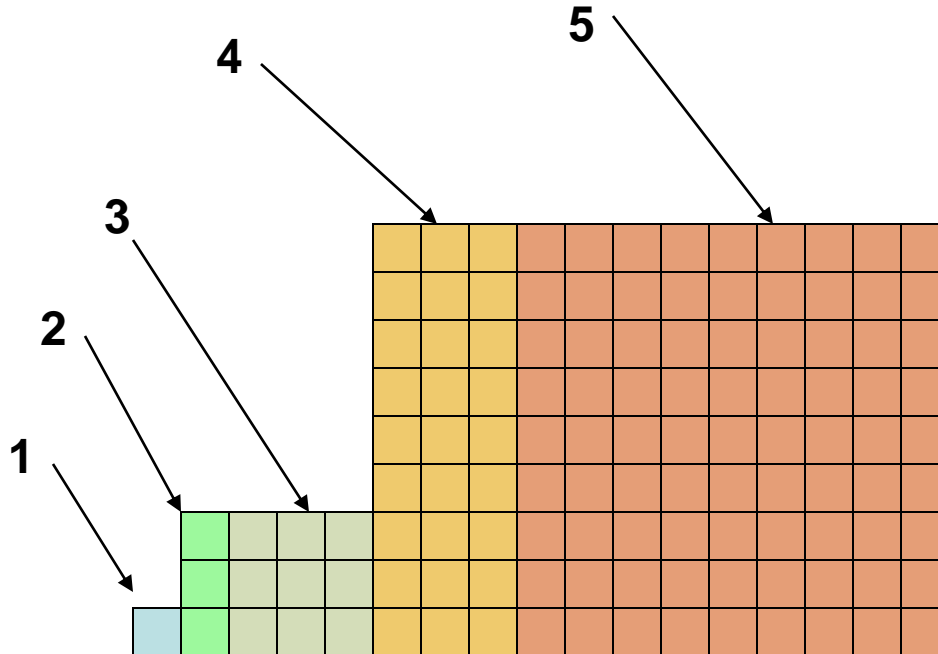



6



7

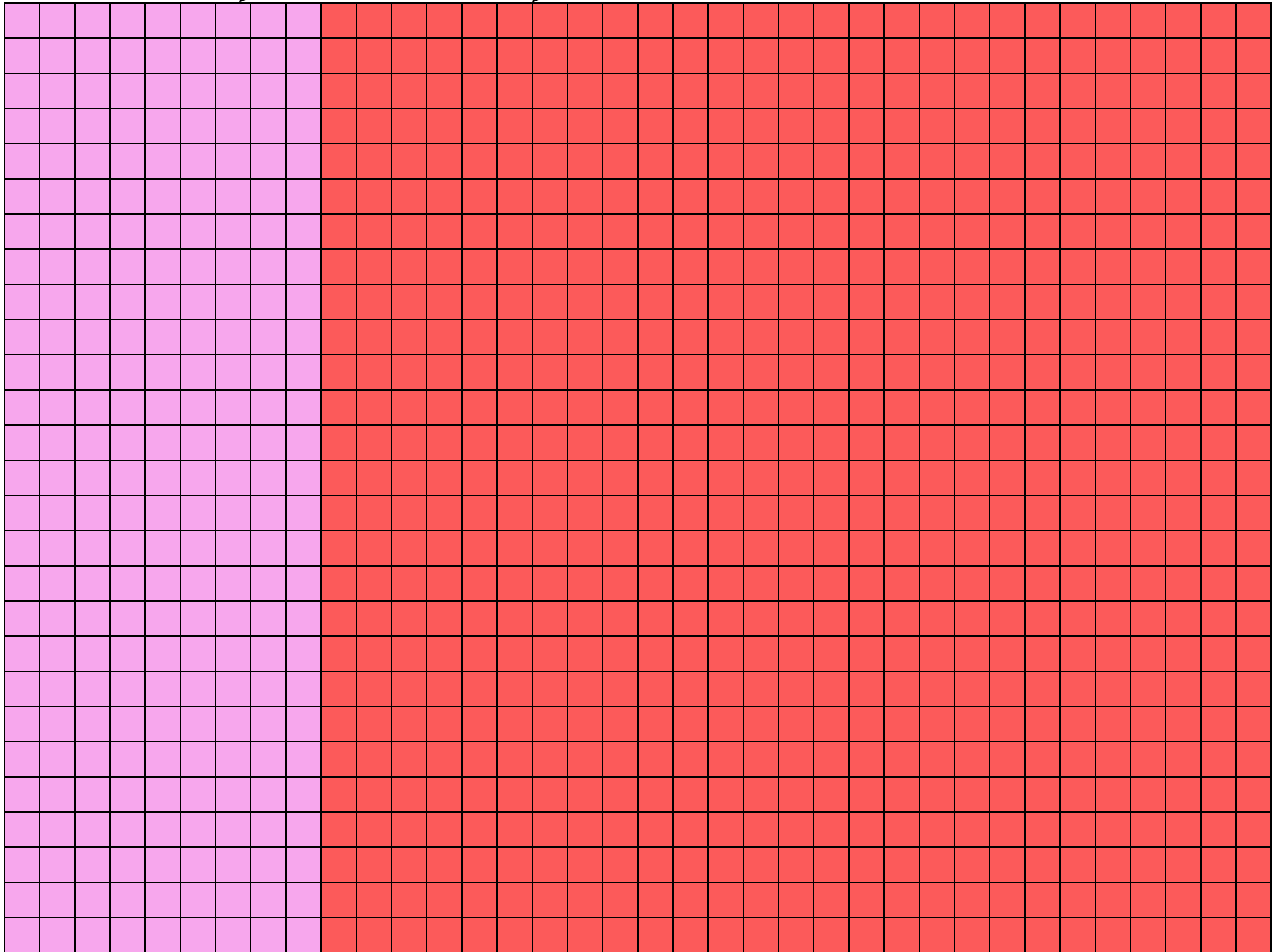

Area of Last Stage Larger than that of all previous stages combined!

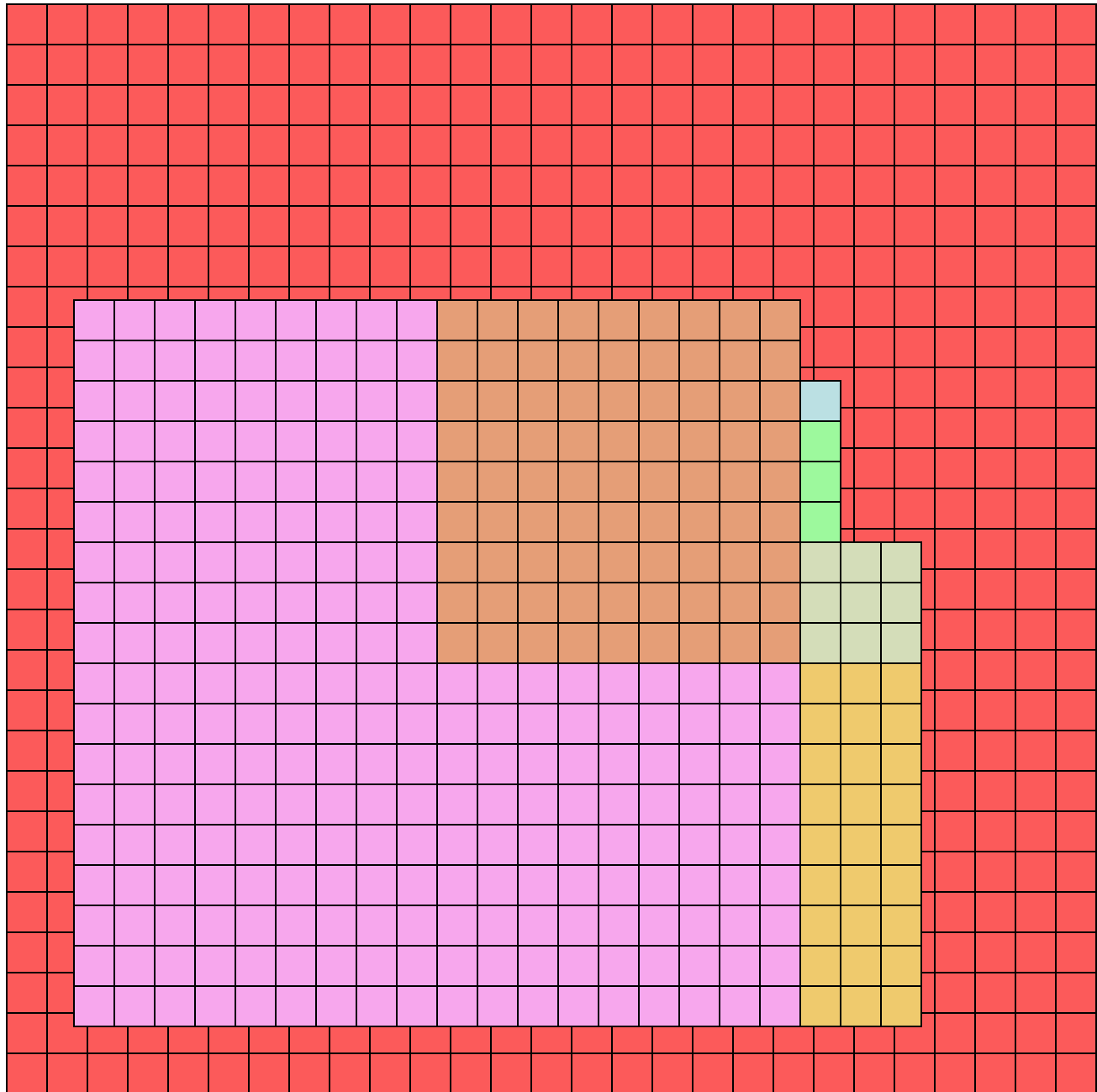



Stay Safe and Stay Healthy !

End of Lecture 42